

# Panasonic®

## Programmable Controller

# FP SERIES FP Web-Server

## Hardware / Configurator



Panasonic®

FP

FP Web-Server Hardware / Configurator

Panasonic Electric Works Europe AG

ACGM0151V2.2END

12/2006

# BEFORE BEGINNING

---

## Liability and Copyright for the Hardware

This manual and everything described in it are copyrighted. You may not copy this manual, in whole or part, without written consent of Panasonic Electric Works Europe AG (PEWEU).

PEWEU pursues a policy of continuous improvement of the design and performance of its products, therefore, we reserve the right to change the manual/product without notice. In no event will PEWEU be liable for direct, special, incidental, or consequential damage resulting from any defect in the product or its documentation, even if advised of the possibility of such damages.

We invite your comments on this manual. Please email us at:

[tech-doc@eu.pewg.panasonic.com](mailto:tech-doc@eu.pewg.panasonic.com).

Please direct support matters and technical questions to your local Panasonic representative.

## LIMITED WARRANTY

---

If physical defects caused by distribution are found, PEWEU will replace/repair the product free of charge. Exceptions include:

- When physical defects are due to different usage/treatment of the product other than described in the manual.
- When physical defects are due to defective equipment other than the distributed product.
- When physical defects are due to modifications/repairs by someone other than PEWEU.
- When physical defects are due to natural disasters.



# Important Symbols

---

One or more of the following symbols may be used in this manual:



## **Warning.**

The warning triangle indicates especially important safety instructions. If they are not adhered to, the results could be:

- fatal or critical injury and/or
- significant damage to instruments or their contents, e.g. data



## ◆ **NOTE**

---

---

Contains important additional information.



## ◆ **EXAMPLE**

---

---

Contains an illustrative example of the previous text section.



## ◆ **PROCEDURE**

---

---

Indicates that a step-by-step procedure follows.



## ◆ **REFERENCE**

---

---

Indicates where you can find additional information on the subject at hand.



## ◆ **CAUTION**

---

---

Indicates that you should proceed with caution.



---

---

## ◆ KEYPOINTS

Summarizes key points in a concise manner.



---

---

## ◆ SHORTCUTS

Provides helpful keyboard shortcuts.



---

---

## ◆ EXPLANATION

Provides brief explanation of a function, e.g. why or when you should use it.

 next page

Indicates that the text will be continued on the next page.

The manual uses the following conventions to indicate elements from the user interface or the keyboard:

"Data Field"	Data field entries and option names are rendered in quotation marks.
[Button]	Buttons are indicated by square brackets.
<Key>	Keys are indicated by pointed brackets

# Table of Contents

<b>1. Getting Started.....</b>	<b>1</b>
1.1 BEFORE YOU START .....	2
1.2 Product Numbers and Versions.....	3
1.3 New in This Version.....	4
1.4 System Requirements .....	6
1.5 Advantages and Functions of the FP Web-Server .....	7
1.6 FP Web-Server Block Diagram.....	10
1.7 System Sample Network .....	11
<b>2. Hardware Description.....</b>	<b>13</b>
2.1 Introduction .....	14
2.2 Hardware Version .....	15
2.3 FP Web-Server Unit Package.....	16
2.4 Parts and Functions.....	17
2.5 Technical Data.....	19
2.6 Installation.....	20
2.7 Important Notes .....	21
2.8 Mechanical Installation .....	24
2.9 Connecting the Power Supply .....	29

---

<b>3.</b>	<b>First Steps.....</b>	<b>31</b>
3.1	Generalities on How to Get Started.....	32
3.2	The Ethernet Network .....	33
3.3	Connection of the FP Web-Server .....	34
3.4	Installation of the Configurator Program.....	35
3.5	Determination of the IP Configuration .....	36
3.6	Generate a New Configurator Project .....	37
3.7	Transfer a Configurator Project to the FP Web-Server .....	39
3.8	Internet Browser to Test the FP Web-Server .....	41
3.9	Further Information.....	43
<b>4.</b>	<b>Configurator Software .....</b>	<b>45</b>
4.1	General Information on the FP Web-Server Configurator .....	46
4.2	Control Buttons for the Administration of the "Configurator Project" .....	48
4.3	Control Buttons for FP Web-Server Control .....	49
<b>5.</b>	<b>Base Configuration .....</b>	<b>51</b>
5.1	Main Configuration .....	52
5.2	Ethernet IP Configuration .....	53
<b>6.</b>	<b>Email Setup.....</b>	<b>55</b>
6.1	Email Functions of the FP Web-Server .....	56
6.1.1	Email Parameters in Configurator Projects .....	56
6.1.2	Predefined Email Texts in the FP Web-Server .....	59

---

6.1.3	Email Function Used for Communication Tests.....	60
6.1.4	PLC Program with Function Block from the Library M_CE_LIB .....	61
6.1.5	Generalities on the Email-Server .....	64
6.1.6	How to Find out the Address of the Email Server .....	66
6.2	Email Configurator Input Fields .....	68
<b>7.</b>	<b>Http Server Functions/ Web Pages .....</b>	<b>69</b>
7.1	Details on the FP Web-Server's Web Page Functions .....	70
7.1.1	Testing the FP Web-Server Functions.....	70
7.1.2	Internet Browser Settings.....	72
7.1.3	Generalities on PLC Data Fields in HTML Pages.....	72
7.1.4	Http Address, CGI Function PLC and Calling Parameter .....	73
7.1.5	Configurator Settings Concerning the Http Server.....	74
7.1.6	Editing HTML Pages .....	75
7.1.7	Compiling and Transferring HTML Pages.....	76
7.1.8	Data Fields for Displaying PLC Data on HTML Pages .....	77
7.1.9	Using Variable Names Instead of Absolute PLC Addresses .....	82
7.1.10	Access Protection for Individual HTML Pages.....	86
7.1.11	Inputs for Controlling PLC internal relays on HTML Pages .....	87
7.1.12	Defining Input Fields for PLC Data on HTML Pages .....	87
7.1.13	Example on Formatting Display and Input Fields .....	92
7.1.14	Automatic Page Reload upon Submitting PLC Data.....	94
7.1.15	Example on Java Script Automations .....	95
7.1.16	Notes on HTML Frames.....	97
7.1.17	Notes on XML Files with PLC Data.....	97
7.1.18	ASCII Character Codes for Strings .....	99
7.2	Configurator Http Administration and Functions .....	100
<b>8.</b>	<b>Ethernet/ RS232C Ports .....</b>	<b>103</b>
8.1	Generalities on the Ethernet/ RS232C Ports .....	104
8.1.1	Server's Side .....	104
8.1.2	Client's Side .....	105



---

<b>9. Dial-In Setup for PPP-Server .....</b>	<b>109</b>
9.1 Dial-up Networking Setup for Computer/ FP Web-Server .....	110
9.1.1 TCP/ IP Network Installation of a Windows Client .....	110
9.1.2 Modem and Dial-up Networking Installation of a Windows Client.....	111
9.1.3 Setup of the Modem Connected to the FP Web-Server for PPP-Communication .....	118
9.1.4 FP Web-Server PPP Gateway Functions .....	119
9.1.5 FPWIN Pro Setup to Use the Remote Dialup Network .....	122
9.1.6 PPP Communication via Null Modem Cable.....	123
9.2 Dial-In Inputs and Parameters for PPP-Server .....	127
<b>10. Dial-Out Setup for PPP-Client .....</b>	<b>129</b>
10.1 The Internet Dial-Out Function .....	130
10.1.1 Internet Email Settings .....	130
10.1.2 Notes for Advanced Users .....	132
10.1.3 When Using a Cellular Phone (GSM) Modem .....	135
10.1.4 GPRS Internet Connections.....	136
10.1.5 When Using ISDN Adapters.....	136
10.2 Internet Dial-Out Settings .....	138
<b>11. NTP Server for PLC Clock Synchronization .....</b>	<b>139</b>
11.1 (S)NTP Servers .....	140
<b>12. Modbus Functions .....</b>	<b>143</b>
12.1 Overview on Modbus-TCP Functions of the FP Web-Server.....	144
12.2 Modbus-TCP Server of the FP Web-Server in General .....	146
12.3 Modbus-TCP Client of the FP Web-Servers in General.....	148
12.4 Appendix for Modbus Functions.....	150

---

<b>13. IEC 60870 Functions of the FP Web-Server .....</b>	<b>151</b>
13.1 IEC 60870 General Functions .....	152
13.1.1 Details of the IEC 60870 Configuration: Modem and Multipoint Settings.....	153
13.2 Parameters for IEC 60870 .....	155
13.3 IEC 60870 Library for Control FPWIN Pro.....	156
<b>14. Java Applet Library "MEW.JAR" .....</b>	<b>157</b>
14.1 Introduction to FP Web-Server and the Java Applet "MEW.JAR" .....	158
<b>15. Additional Information .....</b>	<b>159</b>
15.1 Contents of the CD and Auxiliary Programs .....	160
15.2 Description of the HTML Examples .....	161
15.3 PLC Connection, Cable Drawings, Modem .....	162
15.3.1 PLC Connection .....	162
15.3.2 Cable Drawings and Modem.....	163
15.3.3 Clearing Passwords .....	165
15.4 IP and TCP/ IP .....	166
15.5 Setup of an Individual Ethernet LAN.....	168
15.6 Preinstalled Passwords and Safety Instructions.....	170
15.7 Troubleshooting.....	172
15.7.1 Network Communication Problems.....	172
15.7.2 Problems Finding an FP Web-Server Unit or Unable to Send Configuration.....	174
15.7.3 Panasonic Hotline .....	178
<b>Index.....</b>	<b>179</b>

**Record of Changes**



# Chapter 1

---

## Getting Started

## 1.1 BEFORE YOU START

---

**Please read the following notes on HTML. It will make working with the FP Web-Server easier for you:**

Make sure that you have worked through the First Steps (see page 31) before you try out the HTML functions of the FP Web-Server.

In order to use HTML you do not have to be able to tag or program HTML. Various software is at your disposal:

- Word, Frontpage (delivered with MS Office), Netscape Composer (delivered with Netscape Navigator) et.al. can serve as editors for creating HTML files.
- The created HTML file will be saved on the FP Web-Server with the help of the Configurator.
- A browser (Netscape Navigator, Internet Explorer) is used to display the .htm file.

These software tools provide the logical markup (i.e. text parts are automatically adjusted to any screen format without using a lot of memory) and easy linking that define HTML.

Please refer to the respective software company for questions on software not provided by Panasonic mentioned in this manual (or on the software you chose to work with HTML).

There are two ways to create HTML files:

- **Simple:** You use editors that translate data into HTML automatically. When using these editors, you need no special knowledge about HTML.
- **Advanced:** You create HTML files directly. You need to have knowledge about HTML.

For the FP Web-Server you need to have basic knowledge on how to use HTML.

In case you lack knowledge about HTML, Panasonic provides you with a brief introduction in the section First HTML Page Including PLC Data. In addition, we have inserted examples on HTML (see "Description of the HTML Examples" on page 161) on the CD (supplied with the FP Web-Server). You can install and modify them easily without knowledge of HTML.

## 1.2 Product Numbers and Versions

Item	Product name	Part number
FP Web-Server (Hardware)	FP WEB-SERVER UNIT	FP-WEB (Japan: AFP0610)
	FP WEB-SERVER2 UNIT	FP-WEB2 (Japan: AFP0611)
Configurator Software	FP WEB Configurator Tool Ver.2.11	FPWEBTOOL2 (Japan: AFPS30520-D)
	FP WEB Configurator Tool Ver.2.11 Upgrade	FPWEBTOOLR2 (Japan: AFPS35520-D)
IEC 60870 Communicator	IEC60870 License for FP-WEB	IEC60870LIS
	IEC60870 Communicator FPWIN Pro library (see page 156)	NCL-IEC60870-LIB

You can retrieve information on the following components using the system menu (click on the icon in the upper, left corner or use <Alt>+<Space>) and the "About" box:

- Control FP WEB Configurator Tool
- Serial number
- Name of owner and organization

In the section hardware version (see page 15), you can find out the current version of the hardware.

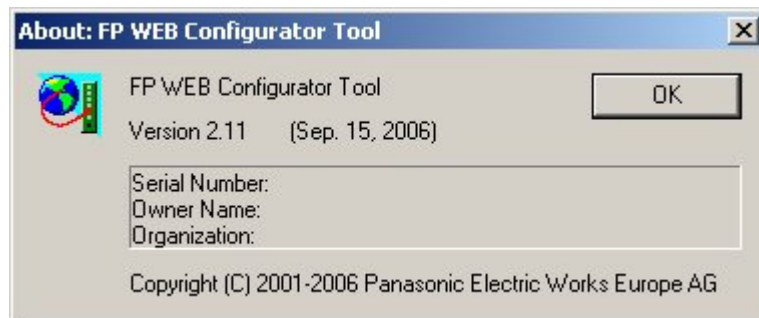

Using the system menu you can also minimize the configurator window.

## 1.3 New in This Version

---

The latest FP WEB Configurator Tool has the following new features:

Version 2.11	07.12.2006	SchB	ZH	Update Release 2.11
--------------	------------	------	----	---------------------

### New Hardware

Type	Description
New feature	Also supports the new FP Web-Server hardware model 2 (see page 15). The selected model is indicated in the status line.

### Email Enhancements

Type	Description
Updated feature	<ul style="list-style-type: none"> <li>- The FP Web-Server can now also log in on email servers which require ESMTP authentication. For detailed information, please refer to Email Server Settings.</li> <li>- When sending an email, the FP Web-Server can now automatically insert a TO and FROM tag line before the email text.</li> <li>- An email attachment (see page 59) (PLC data) can now also be sent in text format.</li> </ul>

### Transparent Port

Type	Description
Updated feature	The transparent TCP port (server and client) was enhanced with RS232C flow control.

### Security Options

Type	Description
New feature	<ul style="list-style-type: none"> <li>- Additional security options can be selected for Internet configurations.</li> <li>- FP-Web-Configurator is included in the WindowsXP firewall exception list during the first, new installation. Administrator rights are needed for the setup.</li> </ul>

### Java Applets

Type	Description
Updated feature	<p>Java applet library (see page 157) with several new functions:</p> <ul style="list-style-type: none"> <li>- ArrayDat.class: Display / Modify an array of PLC Registers</li> <li>- BarGrf.class: Display PLC data as a bar graph</li> <li>- Slider.class: Edit PLC data by a slider</li> <li>- Meter.class: Display instrument with PLC data</li> <li>- IconCtrl.class: Icon display under PLC control</li> </ul>

**Several Minor Updates**

Type	Description
Updated feature	<ul style="list-style-type: none"><li>- Long file names with hardware model 2</li><li>- The "Find" function now finds all units. The list is sorted in order of IP address.</li><li>- The dialogs file "Save As" and "New" have been updated.</li><li>- The button 'Initialize' no longer changes/resets the IP configuration of the unit.</li><li>- System menu items rearranged (compatible with other Windows software)</li><li>- Internet dialup (see page 138), DynDNS update and periodic test improved</li><li>- Modbus-TCP client (see page 148) and server (see page 146) can now also handle UDP broadcasts</li><li>- It is no longer possible to configure a LAN IP address of 0.0.0.0 or x.x.x.255</li><li>- System, hidden and scc files are ignored by the Web file functions</li></ul> <p>The 'old' FP Web-Server Internet demo unit (<a href="http://62.180.233.51/">http://62.180.233.51/</a>) has been switched off.</p> <p>The two new FP Web-Server Internet demo units can now be accessed, also by name:</p> <ul style="list-style-type: none"><li>- Internet demo unit 1: <a href="http://fpwebdemo1.eu/">http://fpwebdemo1.eu/</a> (or <a href="http://62.134.44.202/">http://62.134.44.202/</a>)</li><li>- Internet demo unit 2: <a href="http://fpwebdemo2.eu/">http://fpwebdemo2.eu/</a> (or <a href="http://62.134.44.204/">http://62.134.44.204/</a>)</li></ul>



## 1.4 System Requirements

---

The FP Web-Configurator Tool has the following system requirements:

- MS Windows NT/ XP/ 2000 (or 95/ 98/ ME)
- Hard disk with at least 10 MB free disk space
- Color or monochrome monitor
- Internet Explorer version 5.0 or 5.1 is recommended. Netscape 7.0, Internet Explorer 6.0 and Opera 7.03 have been tested also.
- The user needs administrator rights on his computer to perform the following actions:
  - To install or update the FP Web-Configurator Tool
  - To define a default editor.

## 1.5 Advantages and Functions of the FP Web-Server

The multifunctional FP Web-Server unit allows you to access FP Series PLCs via Ethernet networks (Intranet and Internet) for data exchange.

Access can be carried out by a computer and a standard browser, such as MS Internet Explorer or Netscape Navigator, by specifying the target unit's IP address, which can be changed. The HTML page can be generated with standard tools, such as Netscape Composer, Frontpage or MS Word (not supplied with the Configurator).

### FP Web-Server Advantages:

- Use standard browser, save Scada software
- Use existing Intranet, save wiring
- Representation of PLC data in HTML pages
- Value input and change of values in the PLC (set value, outputs, internal relays) via HTML pages.
- Password protection for access
- Email send function (alternatively via Internet dialup), e.g. for the alarm function (optionally with PLC data attachments)
- Remote programming: remote access via modem (via Dial-up Networking)
- Data transfer: process control system, PLC programming, telemetry, remote maintenance, monitored state function
- Interfacing RS232C serial data via Ethernet, i.e. two FP Web-Servers are used to send RS232C data via Ethernet
- Modem gateway functions to other PLCs equipped with an FP Web-Server

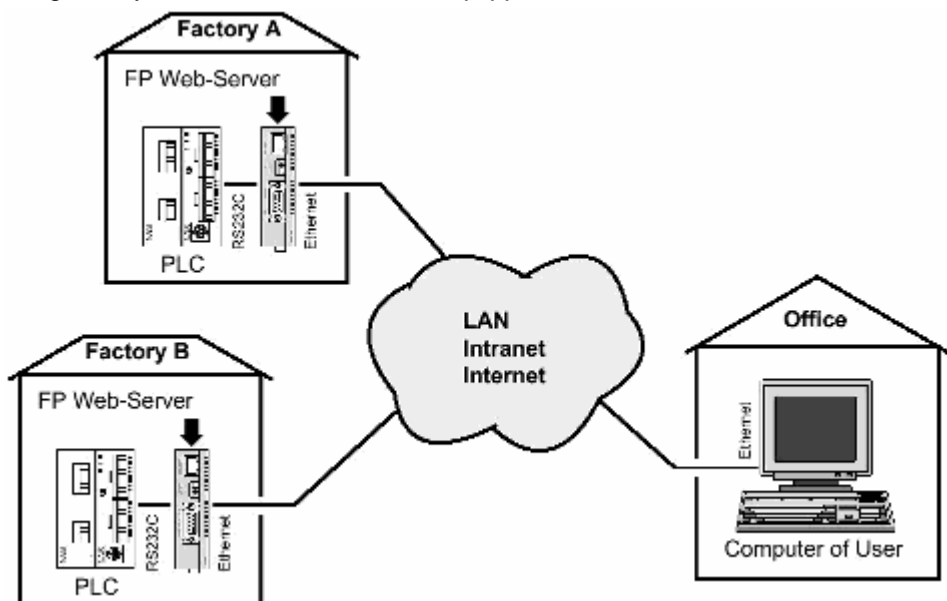

**FP Web-Server Functions:**

The FP Web-Server works as an interface between a LAN or a WAN network (Internet/ Intranet) and all PLCs of the FP Series. The following main features are supported:

**RS232C/ Ethernet Interface (see page 104):**

- RS232C to Ethernet redirection/ conversion
- Programming and visualization tools access via Ethernet
- Optional: password protection and IP lock security
- Optional second, full transparent port

**Web-Server (see page 70):**

- PLC data presented as HTML pages
- Access via standard Internet browser
- HTML entry field for PLC data exchange
- Optional password protection
- Optional PLC data display using Java applets
- PLC data delivery as XML files

**Email (see page 56):**

- PLC can send out an email
- PLC defined or pre-stored email text
- Email sending via LAN or Internet dialup
- Optionally with PLC data attachments

**Modem/ Ethernet Gateway (see "Dial-up Networking Setup for Computer/ FP Web-Server" on page 110):**

- FP Web-Server can be dialed up via modem for local or network access
- One remote gateway for multiple FP Web-Servers provided in a local Ethernet network
- Remote password handling

**Optional IEC60870 protocol (see page 152):**

- IEC60870-5-101 standard telecontrol communication protocol via serial interfaces
- IEC60870-5-104 standard communication protocol via Ethernet
- Optionally with modem support

**Optional Network Time Server (see page 140):**

- PLC real-time clock can be synchronized via NTP server

**The FP Web-Server comes in an FP0 housing and has the following interfaces (see "Hardware Description" on page 13):**

- RS232C interface which can be connected to the PLC (MEWTOCOL protocol)
- Ethernet 10BaseT interface for network connections using the TCP/ IP protocol
- 2nd RS232C interface for an optional modem or for full transparent Ethernet/ RS232C communication

**Configurator Software (see page 45)**

A Windows program is supplied to make the configuration and the setup of the FP Web-Server easy. This configuration program is called "Control FP WEB Configurator Tool". It helps the user to quickly set up and change the following items, e.g.:

- Automatic integration of PLC data into HTML pages
- Preparation of pre-stored mail addresses and texts
- TCP/ IP address and parameter configuration (DHCP is also possible)
- Password and security setup

# 1.6 FP Web-Server Block Diagram

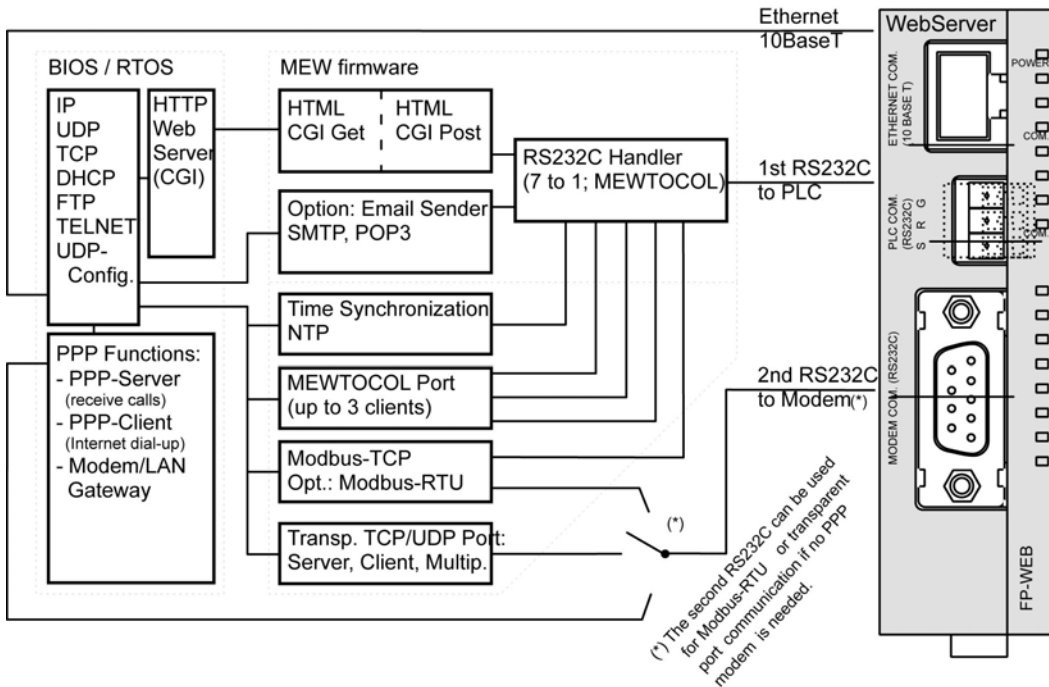

## 1.7 System Sample Network

Any combinations of the LAN and the dial-up functions are possible, e.g. an Ethernet network connecting several FP Web-Servers with one FP Web-Server set up as a gateway for the dial-up connections.

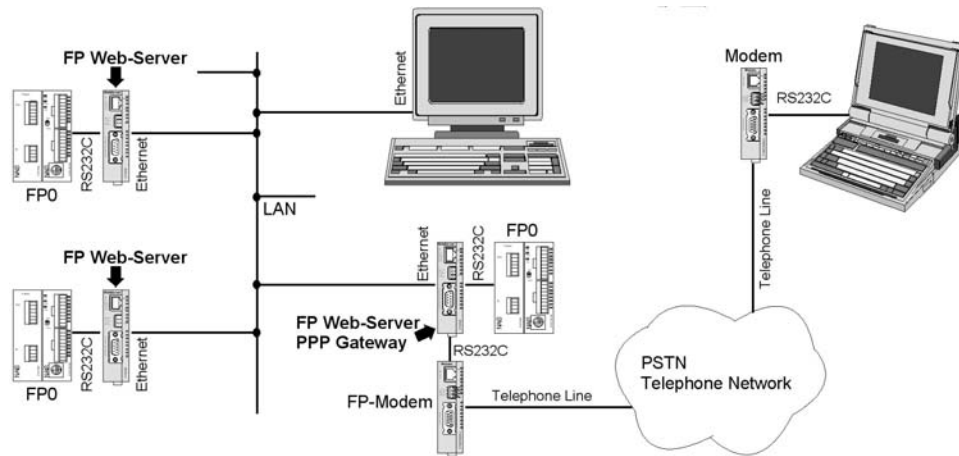



# Chapter 2

---

## Hardware Description



## 2.1 Introduction

---



### ATTENTION !

**Please read the safety instructions in Important Notes (see page 21) and also the section on Mechanical Installation (see page 24) carefully.**

The FP Web-Server allows you to connect the Panasonic FP Series PLCs to an Ethernet Network (LAN).

The FP Web-Server works as an Interface between a LAN or a WAN network (Internet/ Intranet) and all PLCs of the FP Series.

The following main features are supported:

- RS232C/ Ethernet Interface (remote programming monitoring and visualization)
- Web-Server (http server supplies HTML pages with PLC data <See Comments>)
- Email (SMTP protocol)
- Modem/ Ethernet gateway (PPP Server function)
- A Windows program is supplied to make the configuration of the FP Web-Server easy <See Comments>.

See above for a more detailed overview (see page 1) of the FP Web-Server functions. There you can also find a block diagram, a list of features and a brief description.

A data sheet can be found below which also lists the supported standards and protocols.

### Comments:

- A standard HTML Editor (not supplied with the FP Web-Server Configurator Tool) is needed to design HTML Web pages.
- Recommended are Netscape Navigator version 4.7, 4.75 or 7.0, Internet Explorer version 5.0, 5.1 or 6.0 or Opera 7.03 or 7.50. Other versions have not been tested and should not be used.

## 2.2 Hardware Version

---

The unit hardware model and version is printed on the type plate. Two different hardware models are available:

### Model 1: "FP Web-Server" Unit (FP-WEB)

The hardware version 1.2 (available since 2003) is identical to hardware version 1.1 except that the pin assignment of the 9-pin RS232C connector was optimized and the UL approval sign is printed on the unit label.

The latest hardware version is 1.3 (available since the beginning of 2006). It is identical to hardware version 1.2 but with the Panasonic Logo and RoHS conformity.

### Model 2: "FP Web-Server2" Unit (FP-WEB2)

Version 1.0 of this new hardware model will be available at the end of 2006.

The following table presents a brief comparison of the two models.

	FP-WEB2	FP-WEB
<b>Ethernet interface</b>	100Mbps	10Mbps
<b>Application memory</b>	8MB Flash	0.5MB Flash
<b>CPU speed</b>	24 bits at 25MHz	16 bits at 20MHz

### Comment:

The FP WEB Configurator Tool Ver.2.11 can configure all available hardware types and versions.

## 2.3 FP Web-Server Unit Package

---

The FP Web-Server unit package of Panasonic contains:

- one FP Web-Server unit
- a 24V DC power cable
- a leaflet providing installation instructions
- Phoenix 3-pin screw terminal

**Comments:**

- The FP Web-Server network will be configured via the Control FP WEB Configurator Tool.
- The Control FP WEB Configurator Tool can be purchased separately.
- For creating HTML pages a standard HTML editor (not supplied with the Configurator) is required.

## 2.4 Parts and Functions

Below are two illustrations of the FP Web-Server's parts and their functions:

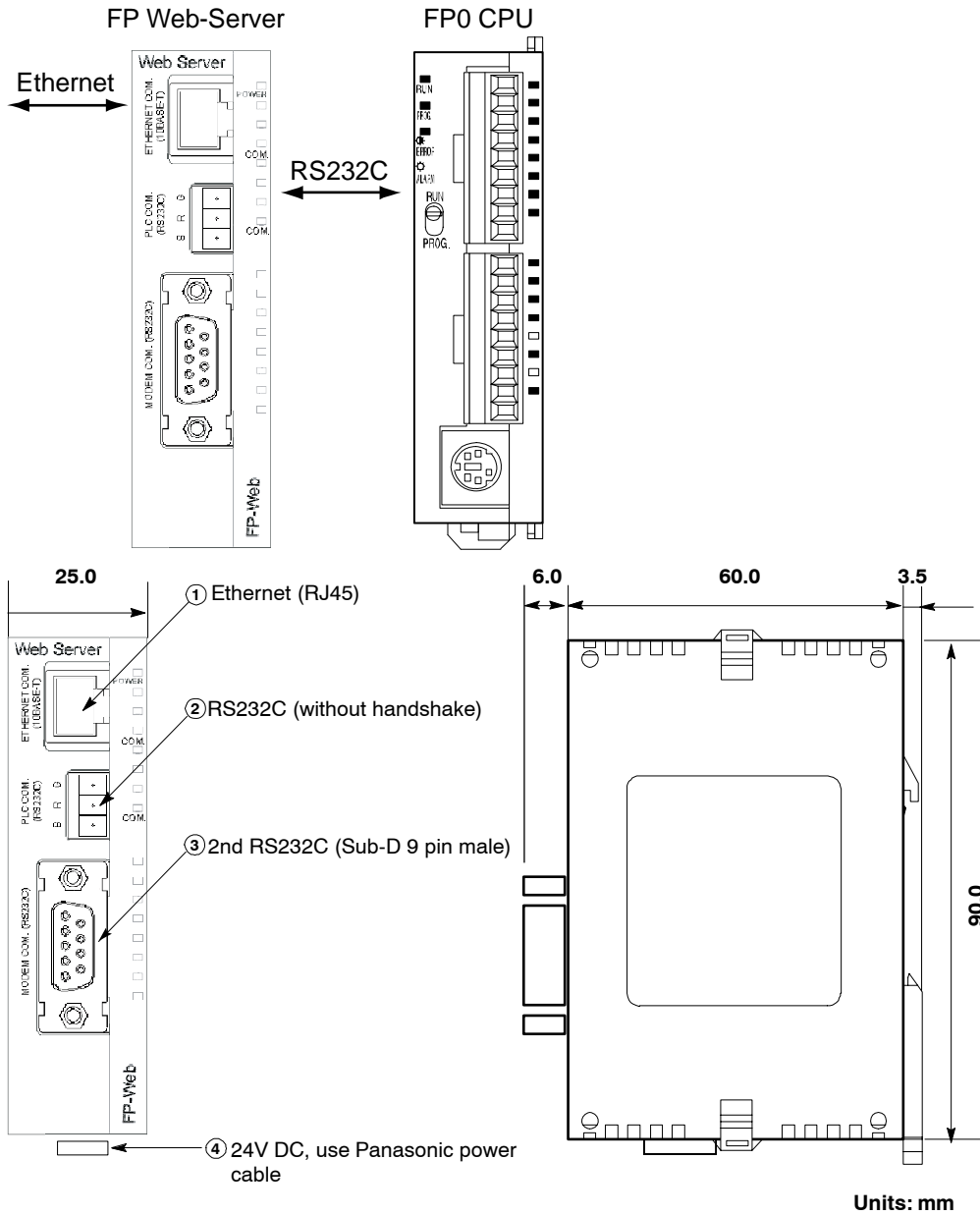

**Note: The green wire MUST be connected to FG!**

- ① **Ethernet (RJ45)**  
(Ethernet 10-Base-T / 100-Base-Tx) use Standard Ethernet CAT.5
- ② **RS232C (without handshake)**  
Screw terminal. Connects to the PLC.

**③ 2nd RS232C (SUB-D 9 male)**

- Compatible to IBM PC serial port.
- Use standard serial computer cables.
  - a) Connects to modem (PPP) or
  - b) Transparent communication with 2<sup>nd</sup> PLC, computer, panel, etc.

**④ 24V DC use Panasonic power cable**

- brown = +24V DC
- blue = GND
- green = framing ground

## 2.5 Technical Data

Feature	Description: Type 1	Type 2
Product number FP Web-Server:	PN Hardware: FP-WEB	PN Hardware: FP-WEB2
	PN Configurator: FPWEBTOOL2	
PLC connection	PLC COM: RS232C via 3-pin screw terminal port Plug: Phoenix product: MC1,5/3-ST-3,5 Order Number: 18 40 37 9	
Modem / 2nd RS232C	Modem COM: RS232C via 9-pin SUB-D port, with RTS, CTS Plug: 9-pin SUB-D female	
Power supply	24V DC Molex 35 plug on the bottom side of the unit	
Ethernet connection	Ethernet-COM: 10BASE-T via RJ45 female connector	10BASE-T / 100BASE-TX autoneg via RJ45 female connector
LEDs	Power, Ethernet, PLC data exchange	Power, Ethernet, Ethernet data, PLC data
Protocols and standards	TCP/IP, UDP/IP, DHCP, FTP, TELNET, http, SMTP, ESMTP-Auth, POP3, PPP, IEC60870, NTP, Modbus, DynDNS	
Flash memory	512KBytes	8MBytes
	For further information, refer to Available Memory Calculation in the online help.	
RAM	512KBytes	8MBytes
Operating voltage	24V DC (10.8 – 26.4V DC supplied by class 2 circuit only)	
Current consumption	Approx. 75mA at 24V DC	Approx. 65mA at 24V DC
Degree of protection	IP20	
Ambient temperature	0°C to +55°C	
Storage temperature	-20°C to +70°C	
Humidity:	Max. 30% to 85% (non-condensing)	
Vibration resistance:	10Hz to 55Hz, 1 cycle per minute with a double amplitude of 0.75mm; 10 minutes every X-, Y-, and Z-axis	
Shock resistance:	Min. 10g; 4 times every X-, Y-, and Z-axis	
Dimensions:	Height 90mm, Width 25mm, Depth 64mm	
Operating conditions:	Free of corroding gases and excessive influence of dust	
CE conformity:	EMV Standard 89/336/EEC 1989EN 55022/Class B EN 55022/Class B; EN 61000-4-2/A1; EN 61000-4-3 EN 61000-4-4; EN 61000-4-6	
UL approval	UL number "2LD7" (file E232530)	UL under preparation
Hardware version	Refer to hardware version (see page 15)	

## 2.6 Installation

---



### ATTENTION!

**Be sure to install the FP Web-Server unit in locations designed for electrical equipment, e.g. in a closed metal cabinet such as a switch cabinet.**

**Make sure you are not electrostatically charged before you touch the FP Web-Server or one of its units: the discharge of static electricity can damage parts and equipment.**

Please install the FP Web-Server in the following order:



### ◆ PROCEDURE

---

- 1. Mount the unit on the DIN rail on which the FP0 PLC is mounted**  
For detailed information refer to Mechanical Installation (see page 24).
- 2. Before connecting the power supply, please read the information on Power Supply (see page 29)**
- 3. Connect the Ethernet (10BaseT) with a standard cable**
- 4. Connect the PLC via RS232C**  
Please read the information on wiring under PLC Connection, Cable Drawings, Modem (see page 162) or the "FP Web-Server Leaflet".
- 5. Configuration: For the first configuration and how to get started with the Configurator please refer to First Steps (see page 31)**

This is a brief description on how to put an FP Web-Server into operation. For a detailed description please also refer to First Steps (see page 31).

## 2.7 Important Notes

---

Please also see the installation sheet "FPWEB\_Server\_Leaflet" supplied with your FP Web-Server for important notes, cables and installation.

Please read the following notes carefully before installing your FP Web-Server.



### ◆ NOTES

---

**1. Avoid installing the unit in the following locations:**

- Ambient temperatures outside the range of 0°C to 55°C/32°F to 131°F
- Ambient humidity outside the range of 30% to 85% RH
- Sudden temperature changes causing condensation
- Inflammable or corrosive gases
- Excessive airborne dust or metal particles
- Fuel, paint thinner, alcohol or other organic solvents or strong alkaline solutions such as ammonia or caustic soda
- Excessive vibration or shock
- Direct sunlight
- Water in any form including spray or mist

**2. Avoid noise interference from the following items:**

- Influence from power transmission lines, high voltage equipment, power cables, power equipment, radio transmitters, or any other equipment that would generate high switching surges.
- If noise occurs in the power supply line even after the above countermeasures are taken, it is recommended to supply power through an insulated transformer, noise filter, or the like.

**3. Measures regarding heat discharge:**

- Always install the unit orientated with the tool port facing outward on the bottom in order to prevent the generation of heat.



- Do not install the unit above devices which generate heat, such as heaters, transformers or large scale resistors.

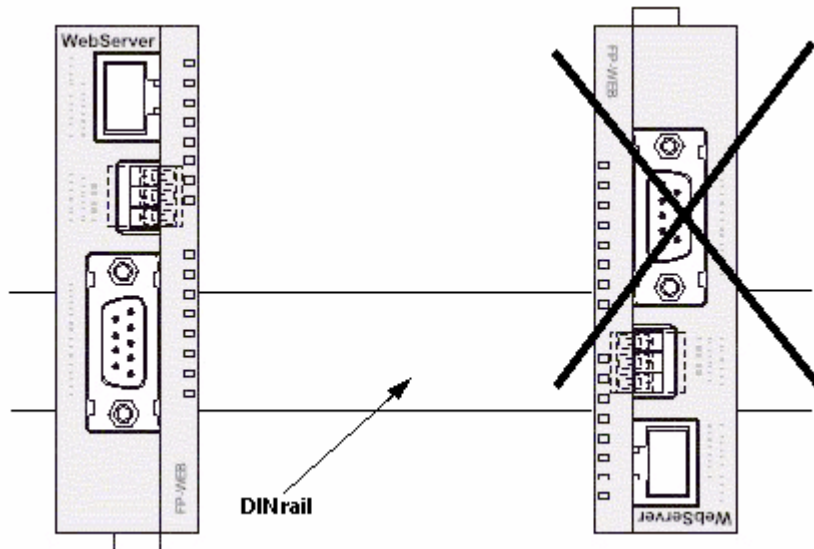

#### 4. Installation space:

- Leave at least 50mm/1.97in. of space between the wiring ducts of the unit and other devices to allow heat radiation and unit replacement.

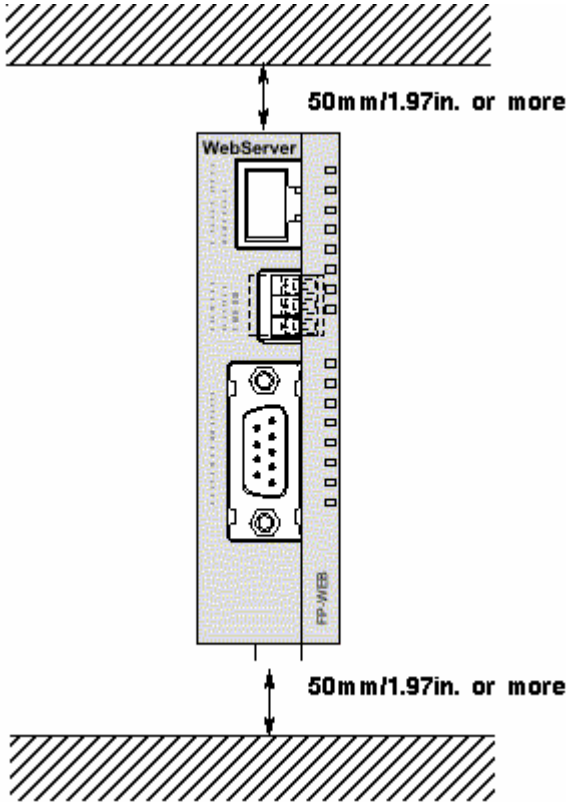

- Maintain a minimum of 100mm/3.937in. between devices to avoid adverse affects from noise and heat when installing a device or panel door to the front of the FP Web-Server unit.

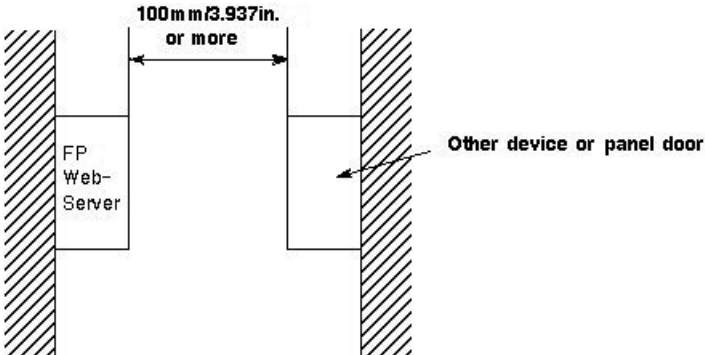

- Keep the first 100mm/3.937in. from the front surface of the FP Web-Server unit open in order to allow room for programming tool connections and wiring.

## 2.8 Mechanical Installation

a) Adding to FP0:



### ◆ PROCEDURE

1. Raise the expansion hooks on the top and bottom sides of the unit with a screwdriver

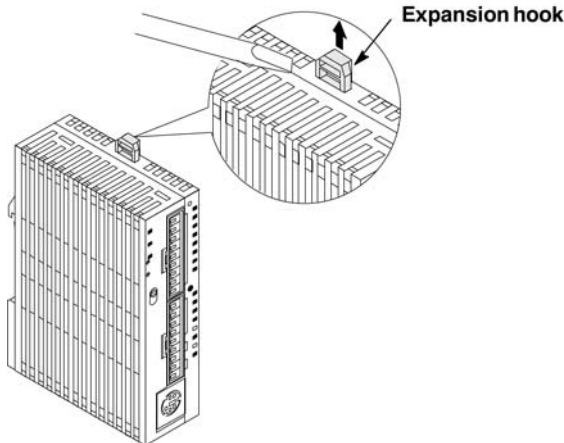

2. You can align the pins and holes in the four corners of the control unit and expansion unit, and insert the pins into the holes so that there is no gap between the units

However you need not necessarily connect the FP Web-Server in this way.

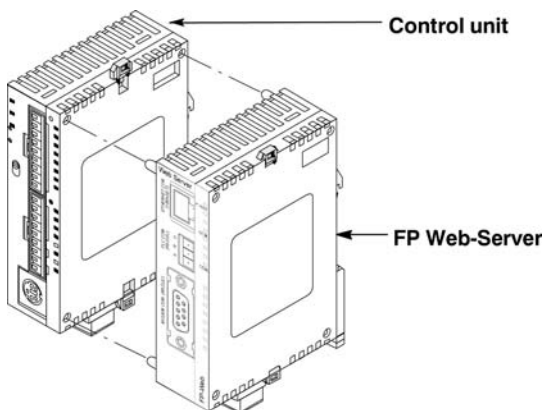

**Note:**

Make sure that the FP Web-Server is the last unit attached. Otherwise the CPU cannot communicate with the expansion units.

**3. Press down the expansion hooks raised in step 2 to secure the unit**

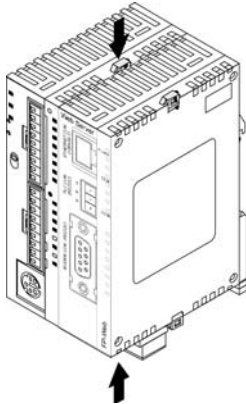

**b) Attachment to DIN Rails:**

- The FP Web-Server unit enables a one-touch attachment to DIN rails.



**PROCEDURE**

1. Fit the upper hook of the FP Web-Server onto the DIN rail
2. Without moving the upper hook, press on the lower hook to fit the FP Web-Server into position

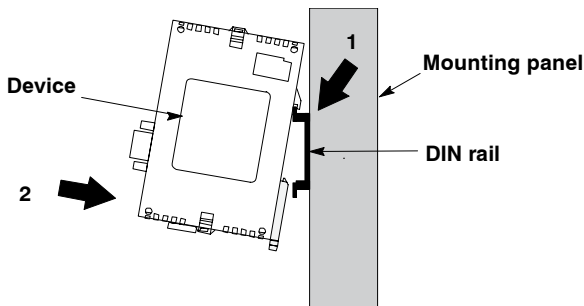

**c) Removal from DIN Rail:**

- You can easily remove the FP Web-Server as described below.



**PROCEDURE**

1. Insert a slotted screwdriver into the DIN rail attachment lever
2. Pull the attachment lever downwards

**3. Lift up the FP0 unit and remove it from the rail**

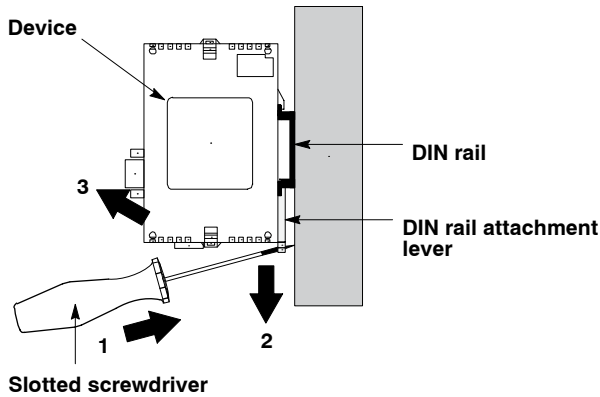

**d) Installation Using FP0 Slim Type Mounting Plate**

- Use M4 size pan-head screws for attachment of FP0 slim type mounting plate (AFP0803) to mounting panel.

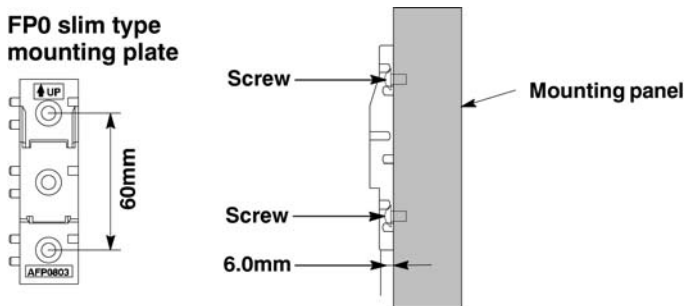

**PROCEDURE**

1. Fit the upper hook of the FP Web-Server onto the FP0 slim type mounting plate
2. Without moving the upper hook, press on the lower hook to fit the FP Web-Server into position

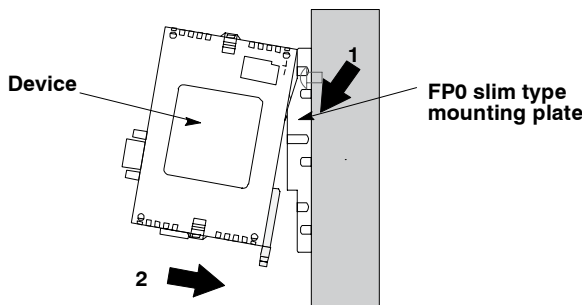

- When using an expansion unit, tighten the screws after joining all of the FP0 slim type mounting plates to be connected. Tighten the screws at each of the four corners.

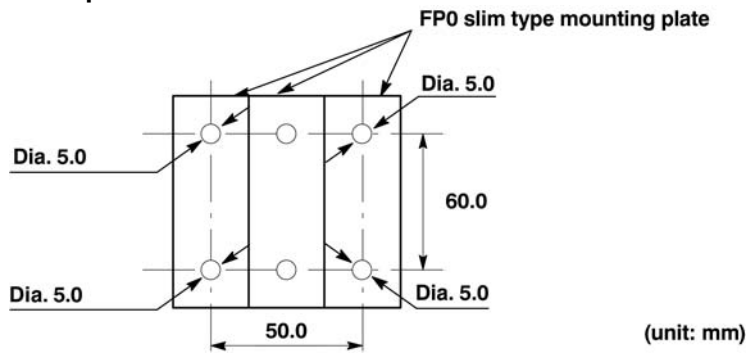
**Example: Two Expansion Units****e) Installation Using FP0 Flat Type Mounting Plate**

- Use M4 size pan-head screws to attach FP0 flat type mounting plate (AFP0804) and install according to the dimensions shown below.

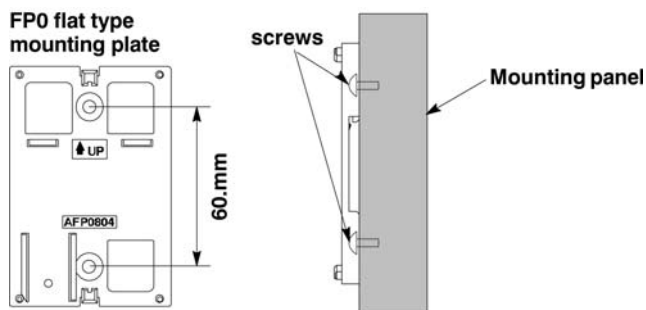
**PROCEDURE**

1. Raise the expansion hooks on the top and bottom of the unit
2. Install the FP0 Web-Server on the FP0 flat type mounting plate

**3. Align the expansion hooks with the plate and press the hooks back down**

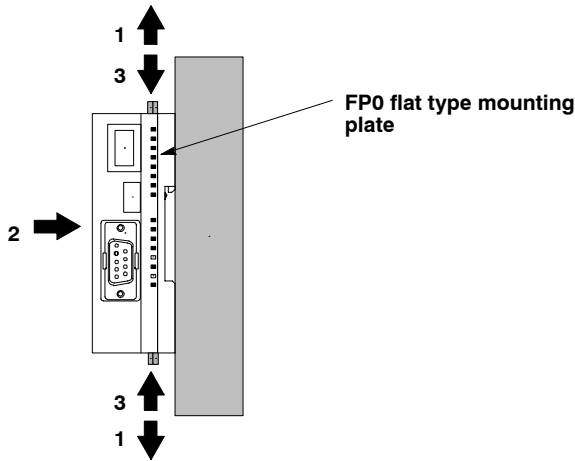

**NOTE**

An FP Web-Server with an attached FP0 flat type mounting plate can also be installed sideways on a DIN rail.

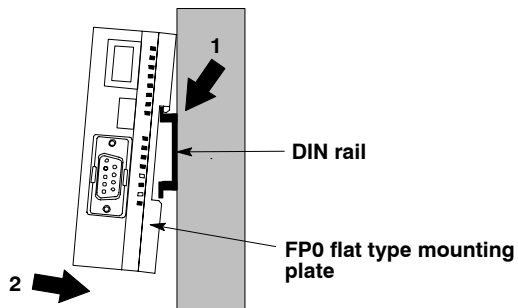

## 2.9 Connecting the Power Supply

---

The FP Web-Server unit will turn ON as soon as the power supply has been connected.



### ◆ NOTES

---

1. When connecting the power supply (class 2 circuit) make sure the polarity (+/-) is correct.
2. The FP Web-Server unit and the PLC have to be supplied by THE SAME power supply unit.
3. If power is supplied, the green POWER LED will be ON.

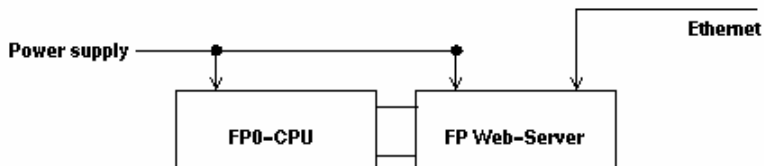

4. Framing Ground (FG) must be connected.
5. Please read the Important Notes (see page 21).
6. Please also read the "FP Web-Server Leaflet" supplied with your FP Web-Server.





# Chapter 3

---

## First Steps

## 3.1 Generalities on How to Get Started

---

For an initial demo of the FP Web-Server's http function, you can access the Panasonic Internet demo unit. To carry out the test, you need an Internet browser.

Please enter the following address: "http://62.134.44.202/" (second demo unit: http://62.134.44.204/)

In the following, putting the FP Web-Server into operation for the first time is described.

The subsequent step-by-step example depicts the general configuration and use of the Web-Server for displaying HTML pages.

To expand upon this example with email functions, refer to Email Functions of the FP Web-Server (see page 56).

For details on programming the email support on the PLC, refer to PLC Program with Function Block from the Library M\_CE\_Lib (see page 61).

For further information, refer to Ethernet/ RS232C Ports (see page 104).

## 3.2 The Ethernet Network

---

The FP Web-Server is supplied with a 10BaseT Ethernet connection. This type of Ethernet network uses a pier to pier connection with twisted pair cables. To establish a network, hubs and switches are used to connect the participants in a star-shaped manner.

To be able to configure the FP Web-Server, a Windows computer with an Ethernet network interface card has to be connected to the same network as the FP Web-Server. The FP Web-Server can be connected to an existing Ethernet network.

It is also possible to set up a separate network for the FP Web-Server. The computer can also be directly connected to the FP Web-Server by using a special "cross-over" Ethernet cable (see page 168).

### 3.3 Connection of the FP Web-Server

---

For an initial function test (without the PLC data), the FP Web-Server has to be connected to the Ethernet and be supplied with operating voltage (24V DC and FG).

In the second step, the FP Web-Server has to be connected to the PLC (via RS232C). The RS232C setting of the PLC must correspond to that of the FP Web-Server. This setting can be defined in the PLC program (FPWIN Pro) under the system parameter settings.



---

**◆ NOTE**

---

**Please remember the ID number found on the FP Web-Server's type label. You will need it when you configure the Web-Server.**

## 3.4 Installation of the Configurator Program

---

To be able to configure the FP Web-Server, a Windows computer with an Ethernet network interface card has to be connected to the same network as the FP Web-Server. The computer must be configured in such a way that it supports the TCP/ IP network protocol.

To install the Configurator (administrator rights are needed), start the setup program on the CD and follow the instructions of the installation program "Control FP WEB Configurator Tool". Various examples (see "Description of the HTML Examples" on page 161) and HTML pages are installed along with the Configurator. In addition, the tool **DnsDisp.exe**, which locates DNS addresses of an Internet Service Provider (ISP), is copied to the installation folder.

### Further information:

- Install the FP WEB Configurator Tool

For detailed information, refer to the file "JavaRuntimeStart.pdf" on your installation CD-ROM in the sub-folder "JavaApplets".

- Contents of the CD and Auxiliary Programs (see page 160)

The Configurator can be started in the Windows start menu under "Program Files/ Panasonic MEW Control/ Configurator/ FP-WEB2/ FP-WEB Configurator 2".

## 3.5 Determination of the IP Configuration

---

Every Ethernet participant must have an individual IP address. This address may not be used a second time in the same network. The IP address (see page 166) consists of 4 numbers (0 to 255). The first numbers define the network address, the other numbers define the participant's address. The IP address of the FP Web-Server can be fixed or it can be allocated dynamically by a DHCP-Server.



### PROCEDURE

---

- 1. In a "self set-up" network (e.g. with only one hub) the IP addresses can be assigned by yourself**

In this case, do not use DHCP. For further information refer to Setup of an Individual Ethernet LAN (see page 168).

- 2. If the FP Web-Server is to be connected to an existing network, the following data must be obtained from the network administrator:**

- Is there a DHCP-Server in the network? If NOT:
- IP address: Which fixed IP address can be assigned to the FP Web-Server?
- Netmask: How is the network address set up (length of the network address and/or the participant's address)?
- Gateway: What is the gateway's IP address? (0.0.0.0 if there is no gateway to be used).

## 3.6 Generate a New Configurator Project

After having started the Configurator, a Configurator project can be opened from the local hard drive with [OPEN]. A Configurator project consists of the configuration plus the email texts plus the HTML pages. Upon the initial start the "default\_project" is automatically offered with [OPEN]. With [OPEN] you can also load one of the examples (see "Description of the HTML Examples" on page 161) (example1 to 9). You can save it under a new name with [SAVE AS]. On the "Config" page you can adjust the following most important settings. At least the following inputs have to be made:

- The IP configuration (see "Determination of the IP Configuration" on page 36) has to be entered accordingly.
- The RS232C parameter to the PLC may have to be adjusted (19200 801 is pre-adjusted).
- It is also recommended to enter an individual user name and a password of your own.
- The http server has to be activated for this initial test. (Please turn off email and PPP!):

The screenshot shows the 'Config' tab of the 'Configurator Project: Example1' window. The 'Ethernet IP Address' section has a checked box for 'Get IP address from DHCP server' and input fields for IP address (199.199.26.52), Netmask (255.255.255.0), and Gateway (0.0.0.0). The 'PLC Interface' section has dropdown menus for Baud rate (19200), Data bits (8), Parity (Odd), and PLC station address (1). The 'Domain Name Server' section has a 'Settings' button and a 'DNS enable' checkbox. The 'Password Protection' section has input fields for 'User name' (user) and 'Password' (masked with asterisks). A 'Summary of enabled Functions' box lists: '\* Http server', '\* MEWTOCOL port server', and '\* Modbus-TCP server + client'. A 'Hilfe' button is at the bottom right.

For the initial test, no other parameters have to be altered. Save the changed project with [SAVE].

### Comments:

- To receive additional help and information on the various Configurator entries, please move the cursor to the respective input field and press <F1>.
- With this version of the FP Web-Server, an HTML online help has been realized. If the help is not displayed (e.g. with Windows95 or Windows NT with service pack 5 or earlier), please install the HTML help work shop from the installation CD. Select "Read me before installing" and click [Install] to set up HTMLhelp.exe. The second installation for the update of the HTML work shop is not needed for the FP Web-Server



configurator.

- The "default\_project" works without PLC data, i.e. it does not need to be connected to the FP Web-Server. Nevertheless, in case "Example1" is used a PLC should be connected.

## 3.7 Transfer a Configurator Project to the FP Web-Server

With [FIND] the network is searched for all FP Web-Servers. A list of all FP Web-Servers found will be displayed. Please select the ID number of the respective FP Web-Server (double-click or press <ENTER>).

If the FP Web-Server is put into operation for the first time (or a new version of the Configurator was installed), please initialize the FP Web-Server ONCE before transferring the project, i.e. click [INITIALIZE] and answer the safety request with [YES].

As there are HTML pages required for this initial test, the checkbox "Web files" should be activated. With [SEND] the project (configuration plus HTML pages) can be transferred to the respective FP Web-Server.

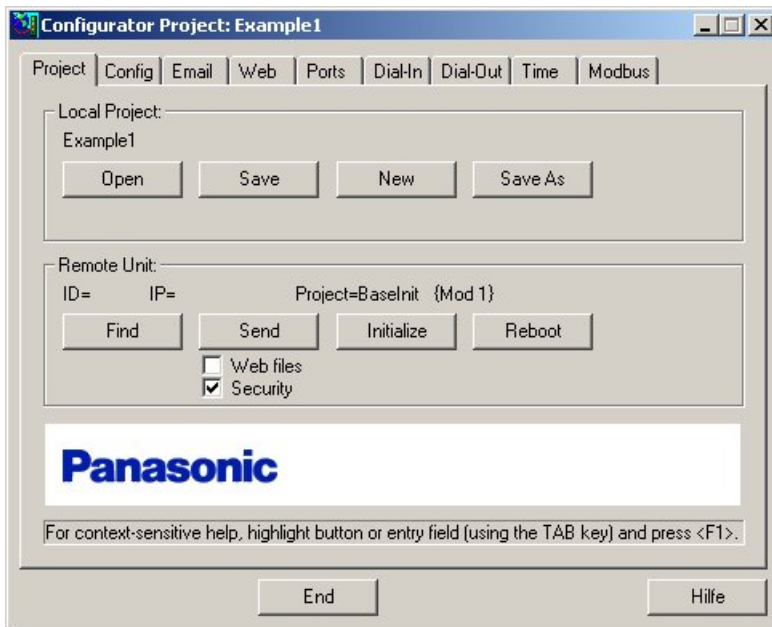

Please click [REBOOT] after transmission. Wait a little bit and then click [FIND] again to make sure that the FP Web-Server is online again and to find out which IP address it is using.

### Comments:

- Please memorize the IP address for the following tests with the browser below.
- If the FP Web-Server was configured with the wrong fixed IP address, a query with [FIND] will result in an error message.
- In this case click [YES]. By doing that the FP Web-Server is set to the IP address entered in the current Configurator project. After a short waiting period, click [FIND] again.

- If the current password of the FP Web-Server is not the same as the password of the project, the user name and the password are asked before transmission and/or restart. ([SEND], [INITIALIZE], [REBOOT]).



- Please refer to "Trouble Shooting (see page 172)" if any problems occur with the functions FIND, SELECT, INITIALIZE or SEND.

### 3.8 Internet Browser to Test the FP Web-Server

The HTML pages of the FP Web-Server can be displayed with a standard Internet browser. Start the Internet browser and enter the IP address of the FP Web-Server into the "Location" field.



The HTML page "MAIN.HTM" of the FP Web-Server will be displayed. For the "Default\_Project" (without PLC data, FP Web-Server may not be connected to a PLC) for example:

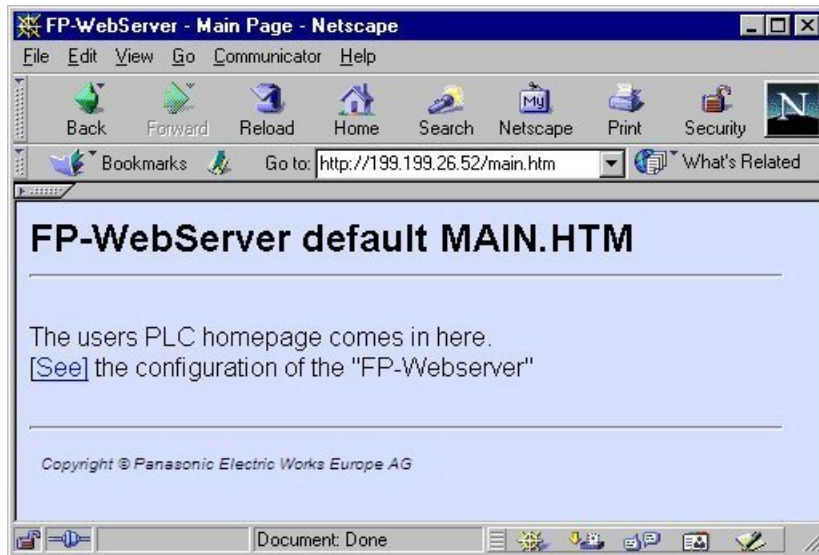

Or for "Example1" (with PLC data):

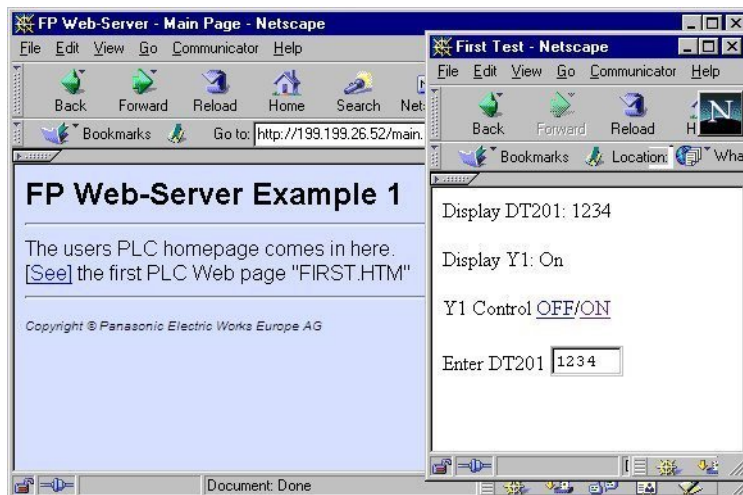

**Comments:**

- In MAIN.HTM you cannot use PLC data items. Furthermore, it is impossible in

MAIN.HTM to use password protection.

- If the FP Web-Server is operated in an office network with a Proxy gateway to the Internet, accessing the FP Web-Server HTML pages might take a long time. In this case, shut off the Proxy function of the browser for this specific IP address of the FP Web-Server. For the browser setup refer also to TCP/IP Setup: Configurator/Browser Operations Via LAN.

## 3.9 Further Information

---

- Details on Web-Server's Web Page Functions (see page 70)
- The PLC sends Emails (Alarm Emails with FPWIN Pro Library (see page 56))
- Details on Ethernet/ RS232C Ports (see page 104)
- Dial-up Networking Setup for Computer and FP Web-Server (see "Dial-up Networking Setup for Computer/ FP Web-Server" on page 110)
- IEC 60870 Functions of the FP Web-Server (see page 151)



# Chapter 4

---

## Configurator Software



## 4.1 General Information on the FP Web-Server Configurator

The FP Web-Server Configurator administers "Configurator projects". These consist of:

- FP Web-Server project file (FP-Web.fpw)
- FP Web-Server configuration (CHIP.INI file)
- IEC 60870 configuration (mew60870.ini)
- Email texts (MAIL\_x.TXT files)
- Web files (MAIN.HTM; \*.HTM; \*.GIF; \*.JPG; \*.XML ...)

Every "Configurator project" is stored in a separate folder. Email text files, .INI text files and a subfolder "http" in which all in Web pages for the FP Web-Server are stored belong to a project.

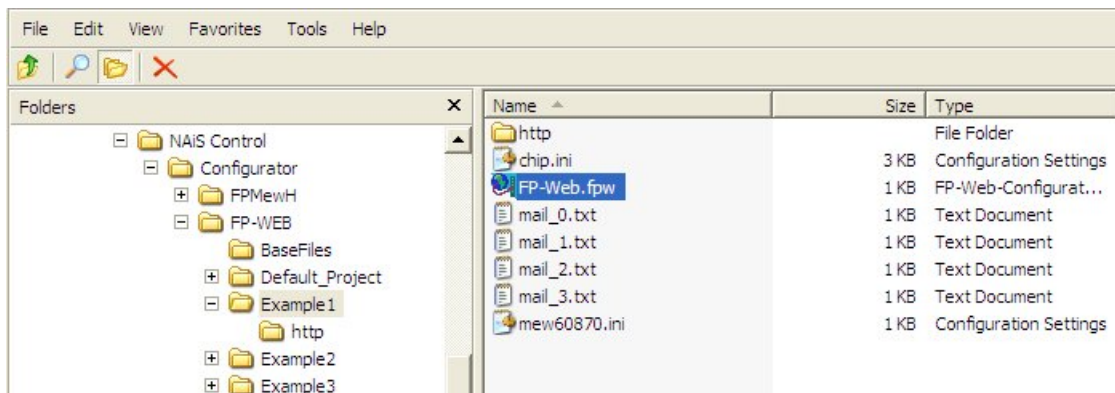

There are 3 ways to start the FP Web-Server configurator:

1. Start -> Program Files ->Panasonic MEW Control/Configurator/FP-WEB2/FP-WEB Configurator 2
2. Double-click the project file \*.fpw of the project within the file explorer
3. Via a DOS command line that includes the configuration to be opened, e.g. C:\Program Files\Panasonic MEW Control\Configurator\FP-WEB2\FP\_Web.exe example1/FP-Web.fpw

To administer ([OPEN], [SAVE]...) "Configurator projects", edit the configuration (including email texts and Web files) and to control the FP Web-Server (transmission of files, initialization, reboot...), the FP Web-Server Configurator provides the following main components:

- Control Buttons (see page 45)
- Base Configuration (see page 51)
- Email Configuration and Texts (see page 55)
- Web files and Editor Call (see page 69)
- TCP/RS232C Ports Configuration (see page 103)
- PPP-Server Configuration (see page 109)

- IEC 60870 Functions of the FP Web-Server (see page 151)
- PPP-Client Dial-Out (see page 138) and
- NTP-Time (see page 140)

In the following sections the individual control buttons of the first page ("project" page) of the Configurator are described in detail:

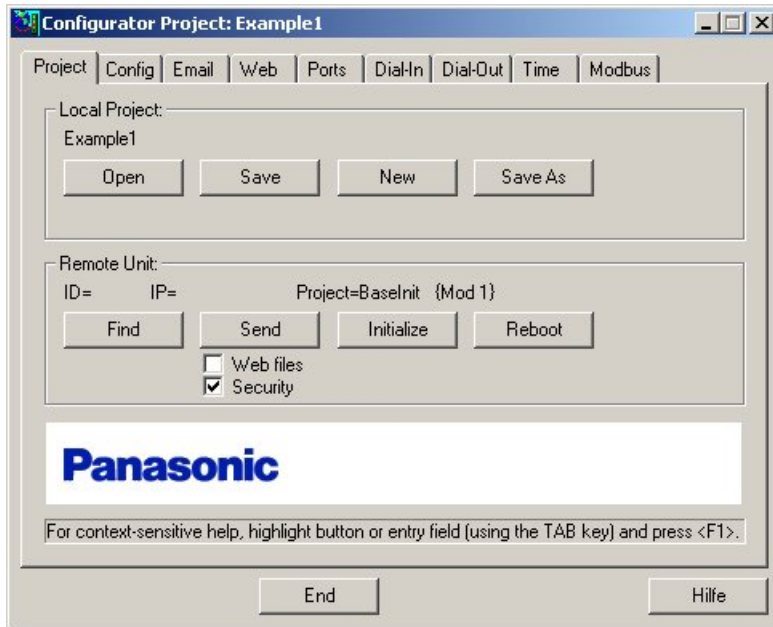

## 4.2 Control Buttons for the Administration of the "Configurator Project"

---

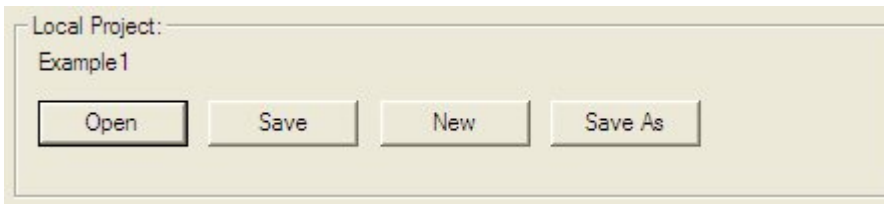

For a detailed description on the control buttons, refer to the online help under the respective keyword of the button.

## 4.3 Control Buttons for FP Web-Server Control

---

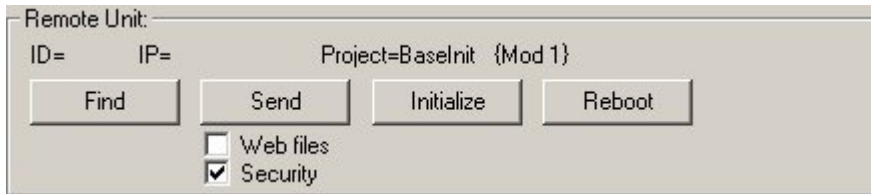

Remote Unit:  
ID=      IP=      Project=Baselnit {Mod 1}

Find      Send      Initialize      Reboot

Web files  
 Security

For a detailed description on the control buttons, refer to the online help under the respective keyword of the button.



# Chapter 5

---

## Base Configuration

## 5.1 Main Configuration

The main settings for the FP Web-Server are adjusted on the "Config" Configurator page. At least the following entries need to be made:

- The IP configuration has to be entered.
- The RS232C parameter to the PLC might have to be readjusted (19200 8O1 is pre-adjusted).
- It is recommended to enter an individual user name and password.
- Depending on which settings are required, the main functions have to be enabled.

The screenshot shows a software window titled "Configurator Project: Example1" with a menu bar containing "Project", "Config", "Email", "Web", "Ports", "Dial-In", "Dial-Out", "Time", and "Modbus". The "Config" tab is active. The window is divided into several sections:

- Ethernet IP Address:** A checkbox labeled "Get IP address from DHCP server" is checked. Below it are input fields for IP address (199, 199, 26, 52), Netmask (255, 255, 255, 0), and Gateway (0, 0, 0, 0).
- PLC Interface:** A section with four dropdown menus: Baud rate (19200), Data bits (8), Parity (Odd), and PLC station address (1).
- Domain Name Server:** A "Settings" button and a "DNS enable" checkbox.
- Password Protection:** Two input fields labeled "User name" (containing "user") and "Password" (containing "\*\*\*\*\*").
- Summary of enabled Functions:** A list of three items: "Http server", "MEWTOCOL port server", and "Modbus-TCP server + client".

At the bottom of the window, there is a text box with the instruction: "For context-sensitive help, highlight button or entry field (using the TAB key) and press <F1>." and a "Hilfe" button.

## 5.2 Ethernet IP Configuration

Every Ethernet participant must have an individual IP address. This address may not be used a second time in the same network. The IP address consists of 4 numbers (any 0 to 255, see also IP and TCP/ IP (see page 166)). The first numbers define the network address, the other numbers define the participant's address.

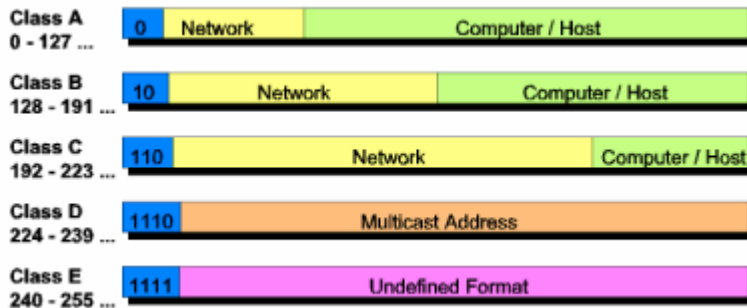

The IP address of the FP Web-Server can be fixed or it can be allocated dynamically by using a DHCP-Server.



### PROCEDURE

- In a "self set-up" network (see page 168) (e.g. with only one hub) the fixed IP addresses can be assigned by yourself**

In many cases a class C network is used. The network is identified by 3 numbers. The participants (Computers, Units, FP Web-Server...) are distinguished by the last number (1 to 254), e.g. 192.168.206.1 to 192.168.206.254.

In case this network is connected to a second network via a gateway (e.g. the computer for configuration might be in this network), the gateway address also needs to be specified, e.g.:

Computer in x.y.206.z Network with Netmask 255.255.255.0, using the x.y.206.1 Gateway.

FP Web-Server in x.y.60.z Network with the following settings:

- IP Add=x.y.60.31
- Netmask=255.255.255.0
- Gateway=x.y.60.1

- In case the FP Web-Server should be connected to an existing network, the following data must be requested from the network administrator:**

- Is there a DHCP-Server in the network? If NOT:
- IP address: Which fixed IP address can be assigned to the FP Web-Server?
- Netmask: How is the network address set up (length of the network address and/or the participant's address)?



- Gateway: What is the gateway's IP address? (0.0.0.0 if there is no gateway to be used).



---

**◆ REFERENCE**

---

For further information please refer to the online help under the keywords "Username and password", "DNS parameter settings", "PLC link interface" or "Selection of the main functions".

# Chapter 6

---

## Email Setup

## 6.1 Email Functions of the FP Web-Server

---

The FP Web-Server can send out emails, e.g. in case of an alert. An existing Email-Server (see page 64) is used to distribute the emails triggered by the PLC. The PLC can use predefined text messages (stored in the FP Web-Server) as well as variably created email texts (stored as ASCII strings in the PLC). The FP Web-Server informs the PLC if the email has been sent out correctly.

After a predefined time interval (e.g. every 7 seconds) the FP Web-Server checks an internal relay of the PLC (via MEWTOCOL) to find out if the PLC wants to send out an email. The polling interval between PLC requests (and the address of the PLC internal relay that starts the sending of the email) can be defined in the Configurator project.

Optionally a file attachment holding PLC data (see page 59) can be generated.

If the http server and/or the Ethernet/RS232C ports are carrying out MEWTOCOL communication with the PLC at the same time, the polling time can take longer than specified in the setup. Especially when carrying out multi-frame MEWTOCOL commands (PLC program download) via the Ethernet/ RS232C ports, the email polling of the PLC internal relay is delayed.

### A) Using an email server via Ethernet LAN:

Please ask your network administrator to clarify the following **requirements**:

- An email SMPT-Server in the LAN is required. Also refer to Setup of an Individual Ethernet LAN (see page 168).
- The address of the Email-Server has to be stated correctly in the Configurator project.
- A defined email address, which is known to the Email-Server, should be assigned to the PLC (or the FP Web-Server).

### B) Dialing up an email server in the Internet:

- A modem is needed to dial up an ISP
- An email account of an Internet email ISP is needed.
- To set up an ISP refer to Internet Email Settings (see page 130).

### 6.1.1 Email Parameters in Configurator Projects

---

The following settings of the Configurator project concern email functionality. (Examples include the Configurator project "Example2" for Ethernet LAN usage and "Example7" for Internet email).

The communication parameters for RS232C to the PLC for email handling is defined in Configurator's tab "Config".

The screenshot shows a window titled "PLC Interface" with four dropdown menus:

- Baud rate: 19200
- Data bits: 8
- Parity: Odd
- PLC station address: EE

Open the "Email" tab in the Configurator for all further settings:

The screenshot shows the "Configurator Project: Example1" window with the "Email" tab selected. The settings are as follows:

- Email sending enable
- Email Server: 199.199.26.20 (Email server address)
- plc@domain.org (Email sender address)
- R 20 (PLC control relay)
- DT 100 (PLC address register)
- 7 (Poll time delay [s])
- Internet Email: See 'Dial-out' section for modem and ISP settings.
- Email recipient address: 0 (set to <user1@domain.com>)
- Email text number: 0 (Automatically generate text lines for  TO  FROM)
- SUBJECT: Email Text 1 (Default "Example1" email text.)

### "Email sending enable":

This setting is used to turn the email function of the FP Web-Server on or off. Disable this checkbox if the email function is not used. This saves the FP Web-Server's memory.

### [Email Server]

Refer to the online help under the keyword Email Server Settings for detailed information.

### "Email server address":

The name of the server or the IP address configured in the Email Server Settings dialog is shown here.

### "Email sender address":

The email sender's address (email address of the PLC, i.e. the FP Web-Server) is defined here. It must be known to the SMTP email server.

Always enter the email sender's address without <> characters!

Japanese characters are not allowed, nor are ASCII characters that contain umlauts.

### [Internet Email: Dial-up and ISP settings]

For detailed information refer to the section Internet Email Settings (see page 130).

**"PLC control relay":**

The PLC internal relay Rxy is prompted by the FP Web-Server and is set by the PLC in case an email has to be sent. Rxy is reset by the FP Web-Server after the email has been sent.

If an error occurs, the Rxy+1 is set by the FP Web-Server after the email transmission. Otherwise the Rxy+1 will be reset.

This setting also has to correspond to the PLC Program (see page 61).

**"DT PLC address register":**

PLC 16-bit DT Address DTzz: For sending the email, the value (**Content**) of the storage location DTzz is read by the FP Web-Server and interpreted as a DT address (**Pointer**), where the string (an FPWIN Pro string with a header) with the recipient's email address begins. If the value of the DTzz lies in the range of 0 to 3, the Recipient's Address defined in the Configurator project is used.

DTzz+1: For sending an email, the value (**Content**) of the storage location DTzz+1 is read by the FP Web-Server and interpreted as a DT address (**Pointer**), where the string (an FPWIN Pro string with a header) with the recipient's email address begins. If the value of the DTzz lies in the range of 0 to 3, the email text defined in the Configurator project is sent (see below).

Data in the FL range cannot be used!

This setting also has to correspond to the PLC program (see page 61).

**"Poll time delay":**

After the time interval has been predefined (for example every 7 seconds), the FP Web-Server checks the internal relay PLC Control Relay of the PLC (via MEWTOCOL) to find out if the PLC wants to send an email.

The "Poll time delay" works in the range of 1 to 60 seconds.

This interval has to agree with the "**Server\_Timeout**" definition in the global variables of the PLC Program (see page 61).

**"Email recipient address: x":**

Predefined email address of the recipient No.0 to No.3: With the [Spin] buttons (arrow up/ down) you can choose among the 4 input fields for the recipient's addresses.

Always enter the predefined email address of the recipient with <> characters!

Umlauts and Japanese characters are not allowed.

A recipient's address can be selected by using the numbers 0 to 3 in the PLC Program (see page 61).

**"Automatic TO and FROM keywords":**

With these check boxes are selected, the FP Web-Server automatically inserts the keywords "To" and "From". For details, please refer to the online help under the keyword "Automatic TO/FROM tag insertion".

**"Email text number: x":**

Predefined email texts (see page 59) No.0 to No.3:

With the [Spin] buttons (arrow up/ down) you can choose among the 4 input fields for the email text input.

A predefined text can be selected by using the numbers 0 to 3 in the PLC program (see page 61).

Optionally a PLC data file attachment (see page 59) can be defined in the email text.

## 6.1.2 Predefined Email Texts in the FP Web-Server

---

Up to 4 email texts (0 to 3) can be predefined in the FP Web-Server, which can be selected and sent from the PLC.

Alternatively the email text can be read from the PLC's memory (see "Email text string in the PLC memory").

The first lines of the email text can be used for special keywords (see RFC 822 regulation):

```
SUBJECT    any subject
TO         any name
FROM       any name
```

To automatically insert keywords, please refer to "Automatic TO/FROM tag insertion".

Then an email text of up to 31950 characters (almost 32kB) may follow. Also the same quantity of characters is allowed when reading email from the PLC.

### Comment:

For email text, use only 7-bit ASCII characters.

The email texts are saved in ASCII text files as "**mail\_x.txt**" in the Configurator project, where **\_x** stands for a number from **0** to **3**. If it is absolutely necessary to edit these files outside the configurator using a text editor (Notepad, EditPad...). Do not work with a word processing system, such as WinWord!

e.g.: The file **mail\_0.txt** from the configurator project may look like the following:

```
SUBJECT: Email Alert
Hello PLC user,
This is an email alert from your
PLC. Service required.
```

### 6.1.2.1 PLC Data Attached to an Email

---

It is possible to generate an email with an attached file holding PLC data. The PLC data can be sent as a text (TXT) or MS Excel (CSV) compatible file format. The PLC register range to be read and sent with the attachment and the file name can be defined in a special tag. This tag is placed in the email text directly after the statements "SUBJECT" and "TO", i.e. in a separate text line directly before the email text starts. The email text can be predefined (stored in the FP Web-Server) or read from the PLC memory.

The format of the special tag for a CSV attachment is:

```
{A_D_00200_00066_S04_filename.csv}
```

or for a text attachment is:

```
{A_D_00200_00001_T01_filename.txt}
```

The parameters in this tag have the following meanings:

Char. Offset	Description	Example
+ 0	Tag must start on line with '{A_'	{A_
+ 3	PLC register type: D=DT F=FL L=LD	D_
+ 5	First PLC register address to read TXT: Start of FPWIN Pro string header	00200_
+11	CSV: Number of PLC registers to read TXT: Always indicator "00001_"	00066_ 00001_
+17	CSV: Cell terminator K=',' S=',' TXT: Always indicator "T"	S T
+18	CSV: Number of CSV columns TXT: Always indicator "01_"	04_ 01_
+21	Attachment file name up to the '}'	filename.xxx

**CSV Example:**

In "Example2" we used the following email text to define an attachment containing PLC data read from the PLC's memory starting at DT200...DT266. It is sent to the email recipient in a CSV compatible file named 'file.csv':

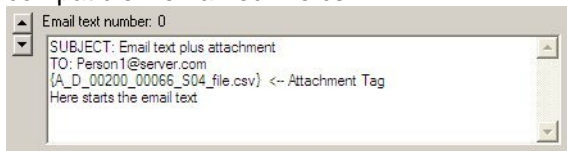

**TXT Example:**

The text to send as an email attachment is stored in the PLC memory as an FPWIN Pro string. The string begins with a 2-word header that defines the maximum and current string lengths. From the third word on, the ASCII character text begins.

For example, a string with the text "message" is stored at DT200:

DT200 = 1000

DT201 = 7

DT202 ...DT205 = "message"



**NOTE**

The tag must start at the first position of the email text after the lines "SUBJECT" and "TO" and before the email text starts.

**6.1.3 Email Function Used for Communication Tests**

Communication tests can be used with empty emails for a DNS request.

For continuous Internet connections (Router, VPN, GPRS ...) it is sometimes necessary to test the communication, i.e. to test the availability of radio connections or to distribute the end unit's IP address after a restart in case bridges or routers are used. In such cases the **DNS request** function for email sending can be used. The PLC should periodically try to send an email ... but the email recipient address should not be set (empty string). Then a DNS request is sent by FP Web-Server (after an optional Internet dialup), which tests the communication. Do not forget to set up the FP Web-Server with a valid email server name and existing DNS server IP address.



## ◆ REFERENCE

For further information, refer to the online help under the keyword "Periodic communication tests".

### 6.1.4 PLC Program with Function Block from the Library M\_CE\_LIB

The following procedure describes how to design a PLC program that sends out an email when you activate a PLC input.

This PLC sample program is thought of as an example for individually developed PLC programs. You can find the library and the program in the installation path "Programs/Panasonic MEW Control/Configurator/FP-WEB2/FPWIN Pro\_Example" of the Configurator. For creating the following PLC program the file "M\_CE\_Tst.asc" (program) and the file "M\_CE\_Lib.sul" (library) are required.



## ◆ PROCEDURE

1. **Copy the files "M\_CE\_Tst.asc" and "M\_CE\_Lib.sul" into a new folder**
2. **Start FPWIN Pro and create a new project**
3. **Select the "Library Pool" in the FPWIN Pro Navigator**
4. **Select and install "M\_CE\_Lib.sul" from the new folder by pressing [Edit], [User Library] and [Install/Create]**
5. **Import the project M\_CE\_Tst.asc with [Project] and [Import Project]**  
Now the project should already be faultlessly translatable. Do not forget to save it.
6. **Double-click "Libraries" in the FPWIN Pro Navigator to open the Library Pool**
7. **Click with right mouse button on "M\_CE\_Lib" and select "Open" from context menu**

Do not enter a password. Open the library with [OK].



**8. Double-click "Global Variables" under "M\_CE\_Lib"**

	Class	Identifier	Mitsubishi	IEC_Address	Type	Initial	Aut	Comment
0	VAR_GLOBAL	MAIL_PLC_CTR_srt	R20	%M00.2.0	BOOL	FALSE		FP Web-Server start sending email
1	VAR_GLOBAL	MAIL_PLC_CTR_err	R21	%M00.2.1	BOOL	FALSE		FP Web-Server error sending
2	VAR_GLOBAL	MAIL_PLC_POI_rec	DT100	%MM05.100	INT	0		FP Web-Server pointer to recipient address string or no.
3	VAR_GLOBAL	MAIL_PLC_POI_txt	DT101	%MM05.101	INT	0		FP Web-Server pointer to text string or file no.
4	VAR_GLOBAL_CP	Server_Timeout			INT	1000		*0.2s FP Web-Server timeout
5	VAR_GLOBAL	mail_add	DT200	%MM05.200	STRING[52]	'per1@server.com'		Variable recipient email address string
6	VAR_GLOBAL	mail_txt	DT300	%MM05.300	STRING[255]	'SUBJECT: Test Email alert from PLC Best regards'		Variable email text string

**9. The following variables have to be compared and adjusted (where necessary) to the settings of the configurator project**

a)

MAIL_PLC_CTR_srt	R20
MAIL_PLC_CTR_err	R21

R 20 R 21 PLC control relay

b)

MAIL_PLC_POI_rec	DT100
MAIL_PLC_POI_txt	DT101

DT 100 DT 101 PLC address register

c)

Server_Timeout	50
----------------	----

50 \* 0,2 = 10s This value needs to significantly exceed the value defined in the poll time delay of the Configurator project! If the FP Web-Server sends an email via Internet dialup the value should be set about 1000s (3 minutes).

d)

The email text stored at the variable 'mail\_txt' in the PLC can contain theoretically up to 32.000 7-bit ASCII characters but FPWIN Pro allows only a maximum string length of 255 characters. This string length can also be set in the Global Variable List.

**10. Select the program "Email Test" in the "POU Pool" and open the "Body"**

It is absolutely necessary to adjust the recipient's email address in network 4. Please use your own email address and do not forget to put the <> brackets around the address.

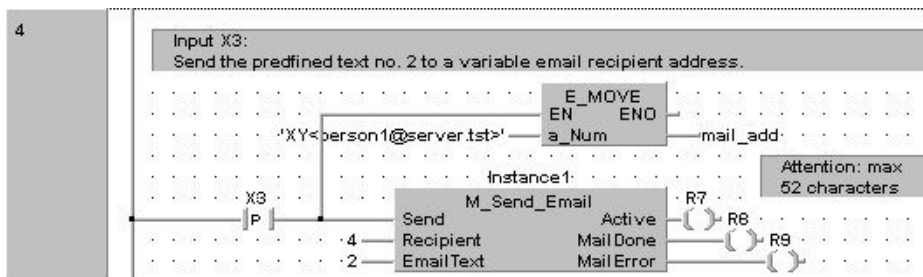

**11. Please make sure that the RS232C parameter of the PLC for the communication with the FP Web-Server is set correctly**

The RS232C parameter of the PLC can be adjusted in FPWIN Pro. The RS232C communication parameter of FP Web-Server to the PLC for the email handling is determined in the Configurator "Config" tab, see also PLC Interface.

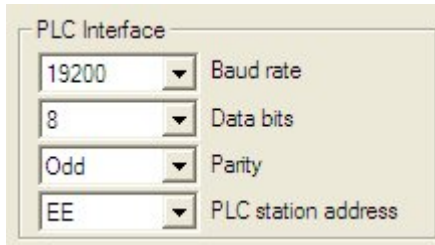

These settings have to correspond to the settings of the respective RS232C ports (TOOL or COM port) of the PLC. To do this, open the "System Register", "Tool Port" or "COM Port" settings in the "PLC Config" and compare and/ or adjust the parameters. The TOOL Port of the PLC always uses an "Odd" Parity:

No	Item Name	Data	Dime...	Range	Additional Information
412	COM port 1 communication mode	MEWTOCOL-COM Slave [Co...		Unused	The MEWTOCOL-COM protocol is used to exchange data between L...
415	COM port 1 unit number	1		1 to 32	Station number (available in 'MEWTOCOL-COM Slave' and 'PLC Link' ...
414	COM port 1 baud rate	19200	baud	115200	Specifies the baud rate of the port.
413	COM port 1 sending data length	8 bits		8 bits	Selects the sending data length.
413	COM port 1 sending parity check	With-Odd		None	Selects the parity check.
413	COM port 1 sending stop bit	1 bit		1 bit	Specifies the number of stop bits.
413	COM port 1 sending header	No-STX		No-STX	Selects the header (available in 'Program controlled' communication ...
413	COM port 1 sending terminator/rece...	CR		CR	Selects the terminator (available in 'Program controlled' communicati...
417	COM port 1 data register starting ad...	0		0 to 5997	Specifies the starting address of the receive buffer (available in 'Pro...
418	COM port 1 receive buffer capacity	0		0 to 2048	Specifies the number of words to be used as a buffer (available in 'P...
416	COM port 1 modem connection	Disable		Disable	Specifies if a modem is connected.

**12. Compile the program, transfer it to the PLC and start it**

Make sure that the FP Web-Server is connected and online.

**13. The program waits for the inputs X1 to X3 and generates the following emails if a positive edge is detected at the input**

Nw 2:	Input X1	Code 1:	Email to a recipient's email address (No.1) that was predefined in the Configurator project.
		Code 3:	Email text (No.3) that was defined in the Configurator project.
Nw 3:	Input X2	Code 0:	Email to a recipient's email address (No.0) that was predefined in the Configurator project.
		Code 4:	Email text that was created by the PLC program in "mail_txt". Max. 255 characters! The sequence of characters \$n stands for a carriage return (CR LF).
Nw 4:	Input X3	Code 4:	Recipient's email address that was created by the PLC program in "mail_add". Max. 52 characters!
		Code 2:	Email text (No.2) that was defined in the Configurator project.

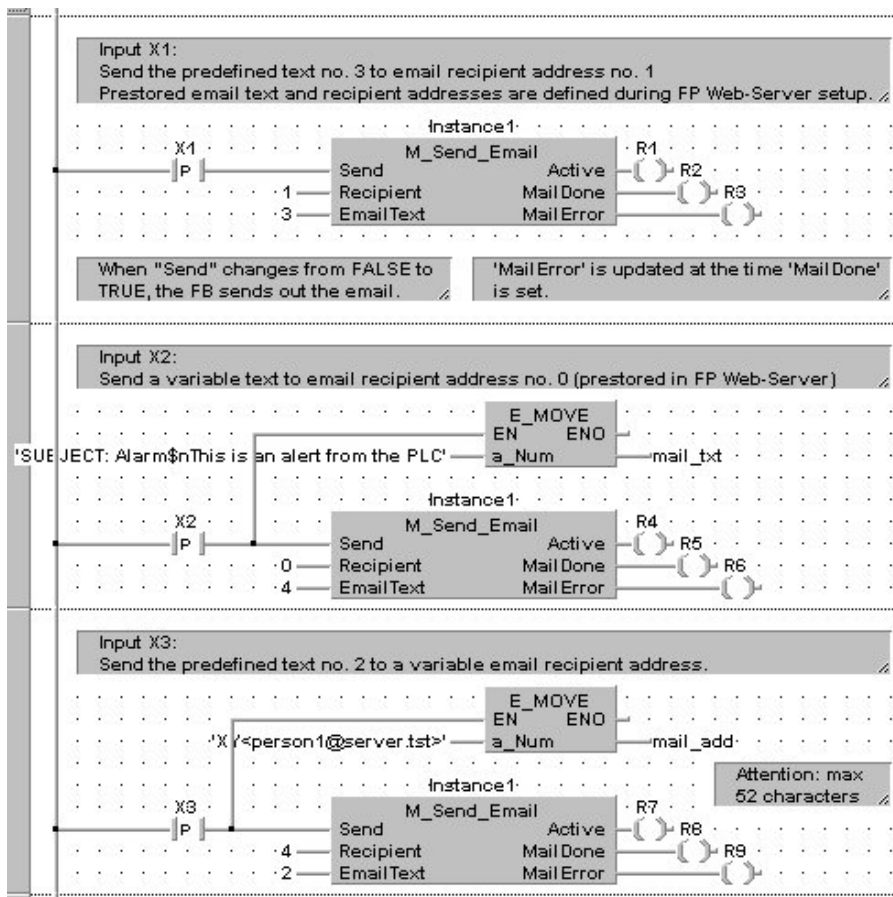

**Output "Active"**

"Active" indicates if the function block "M\_Send\_Email" or the FP Web-Server is still busy sending the email.

**Output "MailDone"**

"MailDone" is set as soon as the sending of the email has been completed. Output "Active" is reset simultaneously.

**Output "MailError"**

"MailError" is reset when the function block is activated. It is set together with "MailDone" in case an email transmission error has occurred.

**6.1.5 Generalities on the Email-Server**

**A) Email-Server in the LAN:**

The FP Web-Server was developed to cooperate with an Email-Server in your local network. Contact your network administrator for detailed information. Often, Email-Servers also allow the transmission of SMS and FAX via email. To send an email to someone via the Internet, the

Email-Server needs to have access to the Internet. This poses no problem if you are using an Email-Server in your LAN that uses the Proxy to the Internet.

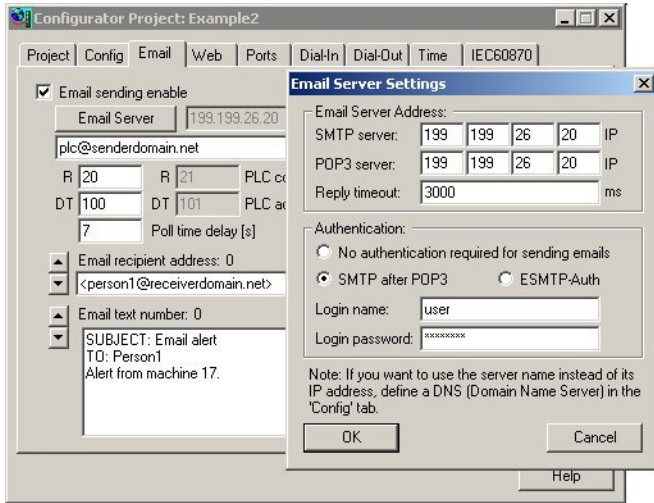

You only need to set the following email server parameters (also refer to the online help under the keyword "Example2" of the HTML examples)

- Server IP address (SMTP server)
- Email sender address

These parameters are available from your network administrator. Optional you can use the server name (DNS is required) and you can log in with a POP3. More detailed information can be found in the online help under email server settings.

## B) Internet email

The FP Web-Server can also use a modem connected to the 9-pin port to dial up the Internet and send emails via an Internet Service Provider.

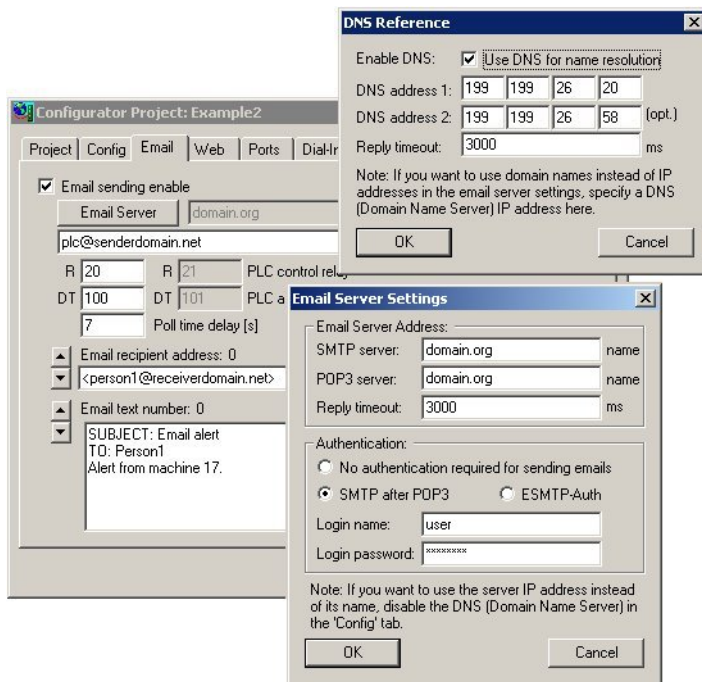

When using this function you need a modem (or GSM module) and the following parameters (also refer to "Example7" of the description of HTML examples).

- Dialup ISP account and DNS server address, for detailed information refer to Internet Email Settings (see page 130)
- Two email server names (SMTP and POP3), for detailed information refer to the online help under email server settings
- Email account with user name and password, also see email server settings
- Email sender address

These parameters are available at your ISP (for detailed information also refer to the online help under email server settings).

### 6.1.6 How to Find out the Address of the Email Server

Normally the name of the email servers can be found on the Internet pages of the email-ISP. See sections on the Internet page called 'Technical details', 'Experts' or 'How to setup email client program'. Please also make sure that no ASMTTP (special encrypted login method) is needed. The FP Web-Server only supports plain 'SMTP after POP3' authentication.

If possible it is recommended to find out the names' IP addresses. You can request from the email-ISP or by using a Windows computer:



## PROCEDURE

1. **Configure and establish a remote network connection to the Internet (via modem)**
2. **At the DOS command prompt, enter the command “PING xyz” which displays the IP address**

```
Eingabeaufforderung
Microsoft(R) Windows NT(TM)
(C) Copyright 1985-1996 Microsoft Corp.
H:\>ping pop3.freenet.de
PING wird ausgeführt für pop3.freenet.de [194.97.55.147] mit 32 Bytes Daten:
Antwort von 194.97.55.147: Bytes=32 Zeit=50ms TTL=56
Antwort von 194.97.55.147: Bytes=32 Zeit=30ms TTL=56
Antwort von 194.97.55.147: Bytes=32 Zeit=30ms TTL=56
Antwort von 194.97.55.147: Bytes=32 Zeit=30ms TTL=56
H:\>_
```

'xyz' indicates where the SMTP (POP3) email server name is.

## 6.2 Email Configurator Input Fields

In the following the individual input fields of the Configurator are described:

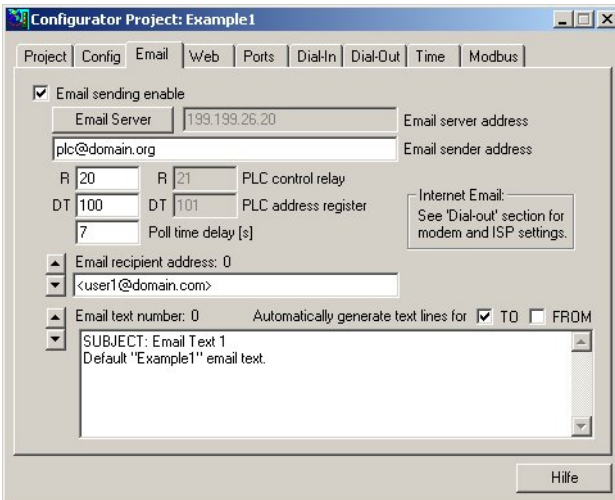

For a detailed description of each field or button in the dialog, set the cursor into the field and press <F1> or highlight the button with <Tab> and press <F1>.

## **Chapter 7**

---

# **Http Server Functions/ Web Pages**



## 7.1 Details on the FP Web-Server's Web Page Functions

---

For an initial demo of the FP Web-Server's http function, you can access the Panasonic Internet demo unit. To carry out the test, you need an Internet browser.

Please enter the following address: "http://62.134.44.202/" (second demo unit: http://62.134.44.204/)

### For further information see:

- **Calling Parameter** (see page 73)  
Browser addressing, e.g. http:\\...\plc?file&Y0=1&A=5&R0=1
- **Data Fields** (see "Data Fields for Displaying PLC Data on HTML Pages" on page 77)  
PLC data display addressing in HTML files, e.g. {DT100\_6\_4.2f}
- **Input Fields** (see "Defining Input Fields for PLC Data on HTML Pages" on page 87)  
PLC data entry addressing in HTML files, e.g. <input name=DT200\_6\_d>
- **Java Applet**  
Description of the optional Java Applets for displaying rapidly changing PLC data
- **HTML Examples** (see "Description of the HTML Examples" on page 161)  
Descriptions for the supplied configuration samples

### Info:

The http server can handle up to 8 simultaneous browser connections.

### 7.1.1 Testing the FP Web-Server Functions

---

For details on how to put a FP Web-Server with HTML Pages in operation, see also First Steps (see page 31). The HTML Pages of the FP Web-Server can be displayed by a standard Internet browser. Therefore, start the Internet browser and enter the IP address of the FP Web-Server in the input field "Location":

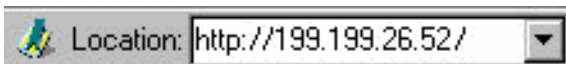

The HTML page "**MAIN.HTM**" of the FP Web-Server will be displayed.

For the "default\_project" (without PLC data, FP Web-Server may not be connected to a PLC) for example:

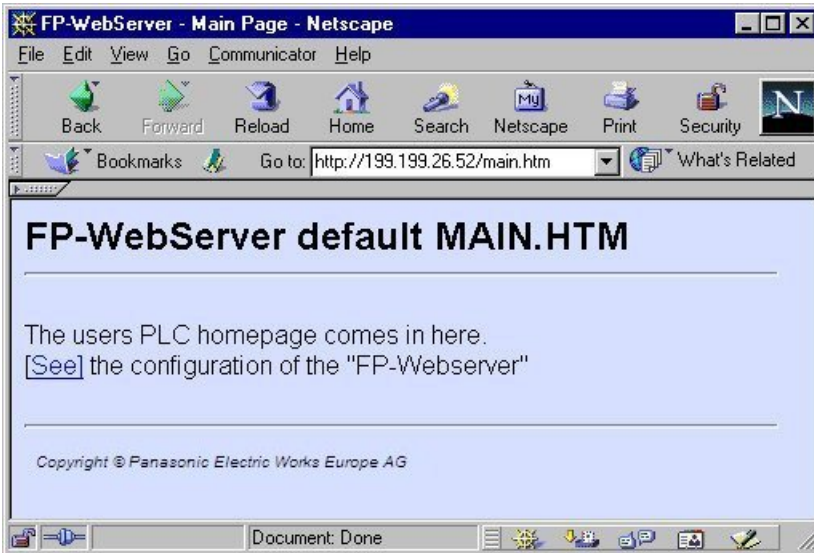

Or for 'Example1' (with PLC Data):

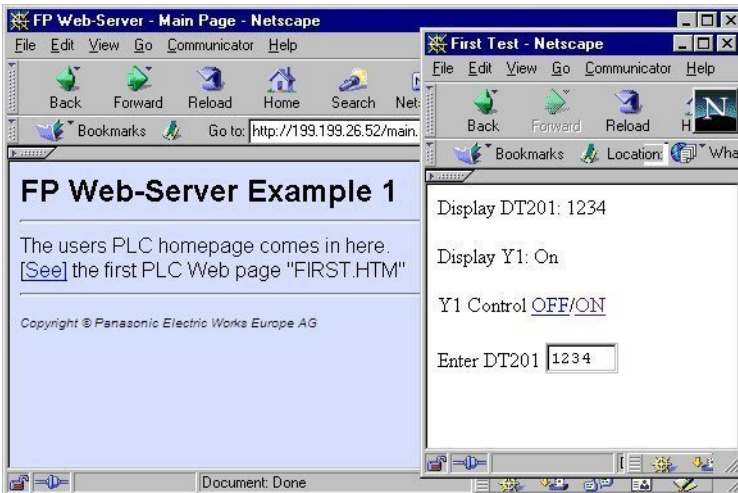

Or for 'Example2':



## 7.1.2 Internet Browser Settings

---

If the FP Web-Server is operated in an office network with a Proxy gateway to the Internet, the access to the FP Web-Server HTML pages might take a long time. In this case, shut off the Proxy function of the browser for this specific IP address of the FP Web-Server. For the browser setup refer also to TCP/IP Setup: Configurator/Browser Operations Via LAN.

## 7.1.3 Generalities on PLC Data Fields in HTML Pages

---

"Example2" (provided in your installation directory) is used for the following explanation:

Here is the HTML page 'MAIN.HTM' of the FP Web-Server displayed. By clicking the links you can test the individual pages. For example, by clicking [Display] the DT200 page (with PLC data) is displayed:

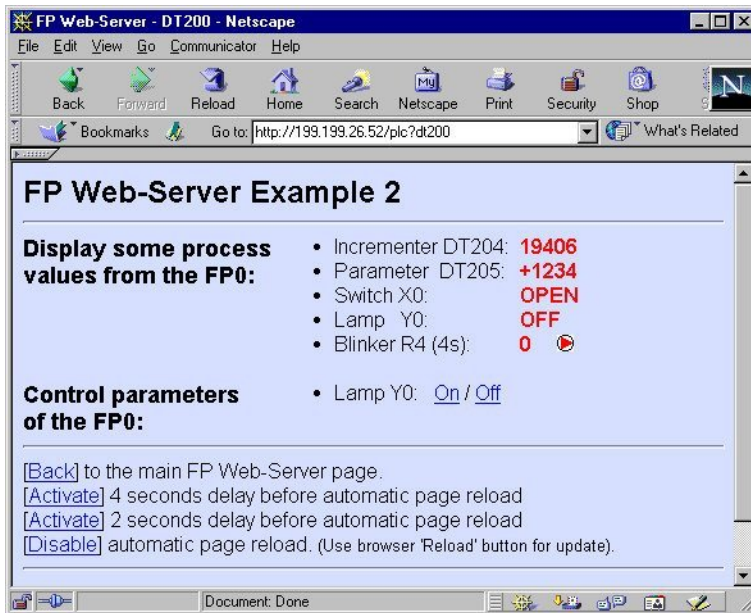

By clicking on [On] or [Off] the output of the PLC can be set.

This page contains PLC data fields whose data address has been entered in the HTML source text. The address is replaced by PLC data upon the calling of the browser. For the format (see page 77) and the input in a HTML code, see also Http Address, CGI Function PLC and Calling Parameter (see page 73).

To accomplish this, the HTML pages that should also display PLC data are marked with the data name extension .MTM instead of .HTM. This is done with the assistance of a "HTML-Compiler" (integrated into the Configurator) before the transmission to the FP Web-Server is carried out by the Configurator.

In the example above, the PLC data are (not necessarily) marked in red. These data were requested from the PLC by the MEWTOCOL Address that is defined in the Configurator project. This "default" MEWTOCOL address can be modified by the calling parameter &A=x in the "Location" field. A description of the parameter can be found under Http Address, CGI Function PLC and Calling Parameter (see page 73).

### 7.1.4 Http Address, CGI Function PLC and Calling Parameter

Please also note the display/input in the "Location" field: "**http://199.199.26.52/plc?dt200**" of the browser. Using the parameter following the IP address you can control various functions.

Http Address	Function
<b>http://199.199.26.52/</b>	Downloads MAIN.HTM (in MAIN.HTM you can neither use PLC data fields nor password protection)
<b>http://199.199.26.52/zzz.HTM</b>	Downloads HTML page zzz.HTM

Http Address	Function
<a href="http://199.199.26.52/plc?yyy">http://199.199.26.52/plc?yyy</a>	Downloads HTML page yyy.MTM including PLC data. The file format .MTM is equivalent to the .HTM format plus PLC data. The .MTM file is generated by the Configurator.
<a href="http://199.199.26.52/plc?yyy&amp;U=xx">http://199.199.26.52/plc?yyy&amp;U=xx</a>	With automatic reload/ update after xx seconds. The maximum refresh rate is reached with the input &U=0. For rapidly changing PLC data, we recommend using Java Applets (see page 158), which can handle a much higher data update/display rate.
<a href="http://199.199.26.52/plc?yyy&amp;A=xx">http://199.199.26.52/plc?yyy&amp;A=xx</a>	All following PLC data displayed (including yyy.MTM) are addressed to the PLC with the C-Net/MEWTOCOL Address xx (0..32). 0 is equivalent to the universal address EE. The default address (if no &A parameter is used) can be determined in the base configuration setting PLC MEWTOCOL Address. The &A operator does not affect the default addressing for input fields.
<a href="http://199.199.26.52/plc?yyy&amp;Rxy=w">http://199.199.26.52/plc?yyy&amp;Rxy=w</a>	Before downloading the page yyy, the internal relay with the address Rxy is set (w=1) or reset (w=0). (xx=0...999 y=0...F w=0/1)
<a href="http://199.199.26.52/plc?yyy&amp;Yxy=w">http://199.199.26.52/plc?yyy&amp;Yxy=w</a>	Before downloading the page yyy, the output with the address Yxy is set/ reset. (xx=0...999 y=0...F w=0/1)
<a href="http://199.199.26.52/plc?yyy&amp;Y0=1&amp;A=5&amp;Y0=1">http://199.199.26.52/plc?yyy&amp;Y0=1&amp;A=5&amp;Y0=1</a>	Composed types of commands are also possible!

#### Comments:

- <http://199.199.26.52/> can be omitted for relative hyperlinks in an .HTM (or .MTM).
- Only when the http server is turned on can the modification of PLC data (via &Y and &R commands) be temporarily turned off. If an error occurs, writing to the PLC may be prevented. Therefore the functioning of the Ys and Rs is also affected.
- The functions &Y and &R can be limited with [Add. Range].
- The name of the CGI function must be in small letters, i.e. "http://199.199.26.52/PLC?yyy" will not work.
- The PLC address of the &R and &Y commands cannot be replaced by a variable name, i.e. "http://199.199.26.52/plc?yyyeR'name'=1" will not work. For further information, refer to Using Variable Names Instead of Absolute PLC Addresses (see page 82).
- If spaces or Japanese characters are used, an error message pops up before transmission to the FP Web-Server.
- All file names have to correspond to the DOS 8.3 format, i.e. the name may only have up to 8 characters and the extension (type) only up to 3 characters after the period. (FP-WEB2 (see page 15): Long file names without special characters can be used.)

For programming examples in C++ and Java to control PLC relays via the http function, please refer to the online help under the keyword "Appendix K) Programming Samples: Access to the FP Web-Server / PLC via TCP".

### 7.1.5 Configurator Settings Concerning the Http Server

Please refer to the online help for the following descriptions:

1. Password Protection
2. PLC Interface Settings
3. Http Server enable (see page 100)
4. Automatic page reload (see page 94) upon submitting PLC data

## 7.1.6 Editing HTML Pages

All web pages the FP Web-Server should be able to display should be created and/ or edited on a computer. To do so, it would be best to mark the respective file of the project in the configurator in the "Web" screen and start the preinstalled editor of the operating system by double-clicking (or pressing <Enter> or [OPEN]). For detailed information, please refer to configurator HTTP administration and functions (see page 100).

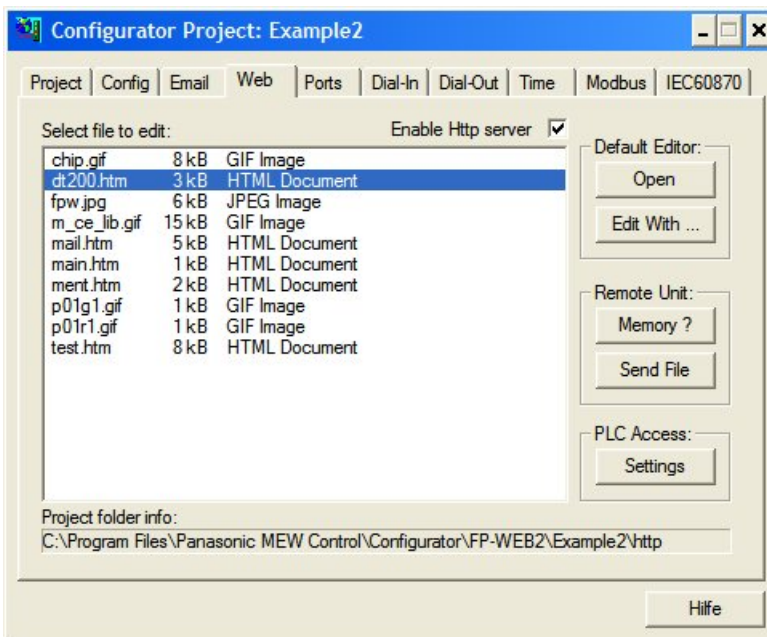

Alternatively you can select an installed editor by pressing [Edit With]. The editor can be an HTML editor or a standard ASCII text editor.

### ASCII Text Editor:

With a standard text editor like the "NotePad" of the operating system, all HTML features can be ideally utilized. Nevertheless it takes time to get used to the HTML format. For training purposes, the following links are recommended:

<http://archive.ncsa.uiuc.edu/General/Internet/WWW/>

<http://www.uni-siegen.de/help/html/>

<http://developer.netscape.com/>

<http://developer.netscape.com/tech/javascript/index.html>

<http://developer.netscape.com/tech/dynhtml/>

<http://WDVL.com/Authoring/HTML/>

<http://whatis.techtarget.com/>

<http://selfaktuell.teamone.de/links/>

The first HTML page that displays PLC data might look as follows (text file):

```
<html>
<head>
<title>Show DT200</title>
</head>
<body>
<p>PLC data DT200: {DT200_5_u}</p>
</body>
</html>
```

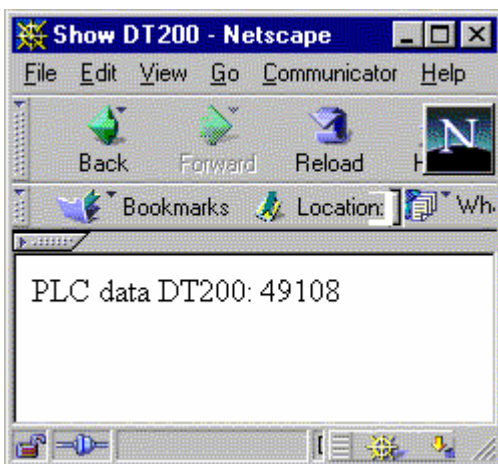

### HTML Editor:

Standard HTML editors like "Frontpage" (Microsoft Browser), "Composer" (Netscape Browser) and "MS-Word" provide many user-friendly functions to design HTML pages. Many browsers also provide an integrated editor (see Netscape Composer in the example below or Frontpage of the IE).

Recommended browsers are:

- Netscape Navigator version 4.7, 4.75 or 7.0
- Internet Explorer version 5.0, 5.1 or 6.0
- Opera 7.03 or 7.50

Other versions have not been tested and should not be used.

## 7.1.7 Compiling and Transferring HTML Pages

To insert PLC data fields into an HTML page, the PLC address information is enclosed in {...} curly brackets. You will find a detailed description of the format of the {...} PLC data fields in the following section. If an HTML page with {...} PLC data fields has been created/ changed, it has

to be transformed into an .MTM file by the "HTML-Compiler" and transferred to the FP Web-Server afterwards.

This is done automatically upon pressing the [SEND] button of the Configurator. If the 'HTML Compiler' discovers an input error, you receive an error message and the location of the error found in the HTML code is displayed. If the compilation is carried out error free, the file .MTM is created and transferred to the FP Web-Server.

An .MTM file corresponds to an .HTM file besides the following issues:

- A Java Script sub-function has been added to the "Header" to display submit confirmations.
- A meta tag has been inserted into the "Header" to control the optional, automatic reload of the page.
- The {...} PLC data fields are replaced by the respective number of spaces.
- The information (addresses, formats...) of the PLC data fields were attached as binary data.



#### ◆ NOTES

---

- **The maximum size of the .HTM and the .MTM file is limited to 64kB.**
- **Please do not use special characters and umlauts in {...} PLC data fields. The following characters are strictly forbidden: " \_ % \ < > & ' ?**

### **7.1.8 Data Fields for Displaying PLC Data on HTML Pages**

---

To integrate PLC data display fields into an HTML page, the following parameters are enclosed in {...} curly brackets and inserted directly at the respective location on the HTML page.

- Data type and data address of the PLC
- Number of display locations on the page (for numbers)
- Specification of the format displayed (format of numbers or text ON/ OFF for internal relay)

The {...} fields can only be seen in the HTML editor (ASCII Text Editor) and are replaced by the respective number of spaces by the "HTML-Compiler". Such a file is then named an .MTM file and saved on the FP Web-Server. Upon the request of an Internet browser, the fields are filled with the current data by the FP Web-Server and displayed by the browser.



Display on the HTML editor (Netscape Composer):

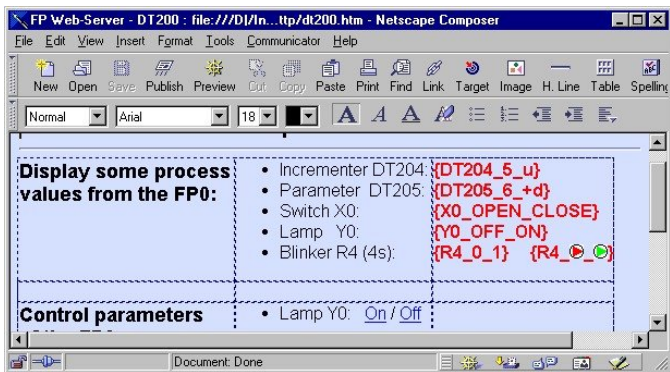

Display on the browser (Netscape Browser):

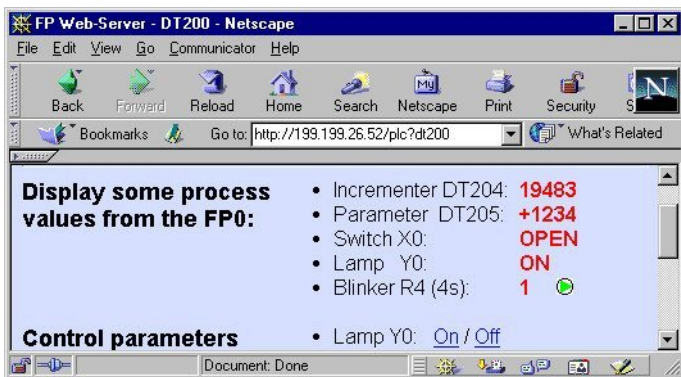

The setup of the field for PLC data display always has the format **{TTxxxy\_aa\_bb}** with the following parameters:

<b>TT</b>	PLC Data Type. Implemented PLC data identifiers: <b>DT, FL, LD, R, X, Y</b>
<b>xxxy</b>	Address of the PLC Data, e.g. DT200 or Y7. The address range supported by the FP Web-Server is 0 ... 32765. For internal relays, the last position of the address is a hexadecimal number from 0...F, e.g. R2F
<b>aa</b>	Numbers: Number of characters reserved in HTML. The rest will be cut off. Internal Relays: Text that should be displayed at internal relay state 0, e.g. <b>OFF</b> .
<b>bb</b>	Numbers: Number format, i.e. type of the display. See below. Internal Relays: Text that should be displayed at internal relay state 1, e.g. <b>ON</b> .

The data type and address part **TTxxxy** can be replaced by the corresponding variable name (see page 82) from the FPWIN Pro project, e.g. **{'VarName'\_aa\_bb}** or **{'name'\_5\_i}**.

There is no space allowed between the curly bracket and the first character. For example **{ DT3\_4\_u}** or **{ 'name'\_5\_i}** is not allowed. It will be interpreted as a Java Script (see page 95) command and copied unchanged into the final HTML file.

The setup of the format specification bb for numbers is **[flags][width][.precision][!]**type****

Only the specification 'type' is obligatory. The other inputs are optional. In the following list the corresponding FPWIN Pro types are listed in brackets:

<b>Type</b>	<b>d</b> = decimal, whole-numbered (16-bit, <b>INT</b> )
	<b>i</b> = decimal, whole-numbered (16-bit, <b>INT</b> )
	<b>u</b> = unsigned decimal, whole-numbered (16-bit, <b>WORD</b> )
	<b>o</b> = unsigned octal (16-bit, <b>WORD</b> ) (only display, not for data entry)
	<b>x</b> = unsigned hexadecimal, lower case (16-bit, <b>WORD</b> )
	<b>X</b> = unsigned hexadecimal, upper case (16-bit, <b>WORD</b> )
	<b>f</b> = floating point number without exponent (32-bit, <b>REAL</b> )
	<b>e</b> = floating point number with exponent (small <b>e</b> for exponent, <b>REAL</b> )
	<b>E</b> = floating point number with exponent (capital <b>E</b> for exponent, <b>REAL</b> )
	<b>g</b> = either <b>e</b> or <b>f</b> , depending on what seems to be more compact ( <b>REAL</b> )
	<b>G</b> = like <b>g</b> , but the exponential display also taken into account ( <b>REAL</b> )
	<b>s</b> = FPWIN Pro strings with current string length in the "Header" ( <b>STRING[]</b> )
	<b>S</b> = string without "Header". Generated like with F95. ( <b>WORD[]</b> )
<b>c</b> = a single ASCII character	
<b>long Type</b>	<b>ld</b> = 32-bit decimal, whole-numbered ( <b>DINT</b> )
	<b>li</b> = 32-bit decimal, whole-numbered ( <b>DINT</b> )
	<b>lu</b> = 32-bit unsigned decimal, whole-numbered ( <b>DWORD</b> )
	<b>lo</b> = 32-bit unsigned octal ( <b>DWORD</b> )
	<b>lx</b> = 32-bit unsigned hexadecimal, lower case ( <b>DWORD</b> )
	<b>lX</b> = 32-bit unsigned hexadecimal, upper case ( <b>DWORD</b> )
<b>precision</b>	<p>A number that defines the number of decimal positions for displaying floating point numbers (types: 'f' 'e' 'E' 'g' 'G').</p> <p>When used with 16- or 32-bit integers (types: 'd' 'i' 'u' 'o' 'x' 'X' 'ld' 'li' 'lu' 'lo' 'lx' 'lX') a decimal point is placed in the integer number string. The number of decimal places defined with the 'precision' ranges from 1 to 9. Refer to Example f.) in Examples to Display PLC Data in an HTML Page (see page 79).</p>
<b>width</b>	A number that gives the minimum length of the field. If the number is shorter, the field is filled up with spaces (or zeroes).
<b>flags</b>	The following characters are permitted:
	<b>+</b> = The algebraic sign (+ or -) is always indicated.
	<b>0</b> = Leading zeroes are indicated.
	<b>' '</b> = (blank character) Prefix the output value with a blank if the output value is signed and positive.
	<b>#</b> = Forces the output value of the e, E, or f format to contain a decimal point (but only if digits follow). When used with the g or G format, the # flag also prevents the truncation of trailing zeros.

### 7.1.8.1 Examples to Display PLC Data in an HTML Page

a) Signed and unsigned Integers

Format	PLC value	Display
{DT201_5_d}	-1 (FFFFhex)	"-1 "(same as {DT201_5_i})
{DT201_5_u}	-1 (FFFFhex)	"65535"
{DT201_6_d}	-32768 (8000hex)	"-32768"
{DT201_5_u}	-32768 (8000hex)	"32768"

Format	PLC value	Display
{DT201_6_+d}	12345 (3039hex)	"+12345"

b) Spaces and zeros

Format	PLC value	Display
{DT201_6_i }	DT201=17	"17 " (HTML suppresses multiple spaces)
{DT201_6_06i}	DT201=17	"000017"
{DT201_6_6i}	DT201=17	" 17" (HTML suppresses multiple spaces)
{DT201_6_6.0i}	DT201=17	" 17" (HTML suppresses multiple spaces)

c) Hex display

Format	PLC value	Display
{DT201_4_4X}	DT201=17	" 11" (HTML suppresses multiple spaces)
{DT201_4_04X}	DT201=17	"0011"
{DT202_8_08IX}	DDT202=123456	"0001E240" (lower case L before X)
{DT202_8_8lx}	DDT202=123456	"1e240" (lower case L before X)

d) Float (real value) display

Format	PLC value	Display
{DT202_8_f}	DDT202=6.7 (40D66666hex)	"6.700000"
{DT202_8_7.2f}	DDT202=12345 (4640E400hex)	"12345.00"
{DT202_8_7.2f}	DDT202=23.456 (41BBA5E3hex)	" 23.46 "
{DT202_8_+7.2f}	DDT202=1234.56 (449A51EChex)	"+1234.56"
{DT202_13_e}	DDT202=123.4 (42F6CCCDhex)	"1.234000e+002"
{DT202_13_E}	DDT202=1234000 (4996A280hex)	"1.234000E+006"
{DT202_10_g}	DDT202=123.4 (42F6CCCDhex)	"123.4 "
{DT202_10_g}	DDT202=1234000 (4996A280hex)	"1.234e+006"

e) Display strings

Format	PLC value	Display
{DT602_5_S}	DT602-DT606="ABCDEFGHJIJ"	"ABCDE"
{DT602_5_3S}	DT602-DT606="ABCDEFGHJIJ"	"ABC "
{DT600_12_s}	DT600=34 DT601=10 DT602-DT606="ABCDEFGHJIJ"	"ABCDEFGHJIJ "
{DT600_6_s}	DT600=34 DT601=10 DT602-DT606="ABCDEFGHJIJ"	"ABCDEF"
{DT602_5_c}	DT602-DT606="ABCDEFGHJIJ"	"A "
{DT602_1_c}	DT602-DT606="ABCDEFGHJIJ"	"A"

f) Examples of displaying integers with a decimal point

With the latest version the '.precision' (range 1...9) format specification can be used

to insert a decimal sign into an integer display.

Format	PLC value	Display
{DT201_7_3i}	DT201=1234	1.234
{DT201_6_4d}	DT201= -12	-0.0012
{DT201_7_05.2d}	DT201= 17	000.17
{DT201_16_4lu}	DDT201= 12	0.0012
{DT201_5_2X}	DT201= 12	0.0C

g) Relay register (1-bit) display:

Format	Display FALSE	Display TRUE
{R901D_0_1}	"0"	"1"
{R901D_off_on}	"off"	"on"
{R901D_0_1_2_3}	"0"	"1_2_3"
{R901D_<img SRC="icn1.gif">_ON}	Image icn1.gif	"ON" <b>Note:</b> Do not use spaces or the character '_' in file names

**Further examples:**

Additional basic format examples can be found in the online help under "Example2" and enhanced HTML PLC data formation in "Example13".

For PLC data entry (see page 89) the same tags are used for formatting.

**7.1.8.2 Comments**

- The PLC data tag can also be used in XML files for data exchange. Please find details under "Notes on XML Files with PLC data (see page 97)".
- In the text parameters **aa** and **bb**, which specify texts for the internal relay's statuses, it is also possible to use complex HTML blocks, e.g. to display graphics.
- Please do not use special characters and umlauts in {...} PLC data fields (and/ or the format parameters aa and bb). The following characters are strictly forbidden: " \_ % \ < > & ' ?
- PLC data display fields can also be used in the [VALUE] field of the [SUBMIT] input fields to indicate an (editable) output value.

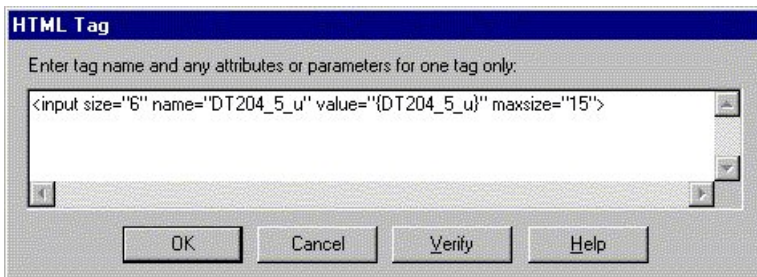

- Strings to be displayed have a maximum length of 52 characters. For PLC data input fields, only strings with 48 characters are possible.
- The special characters < and > are transcribed as ¼ and ¾ characters when a string is

displayed on an HTML page. Please refer to ASCII Character Codes for Strings (see page 99).

- The "default" MEWTOCOL address can be modified for the current browser's request of this page with the calling parameter &A=x .

If an HTML page from FP Web-Server is requested by the browser but the PLC data cannot be read out from the PLC (Baud Rate, Problems with Cables...), an HTML page with an error message will be displayed instead of the requested page.

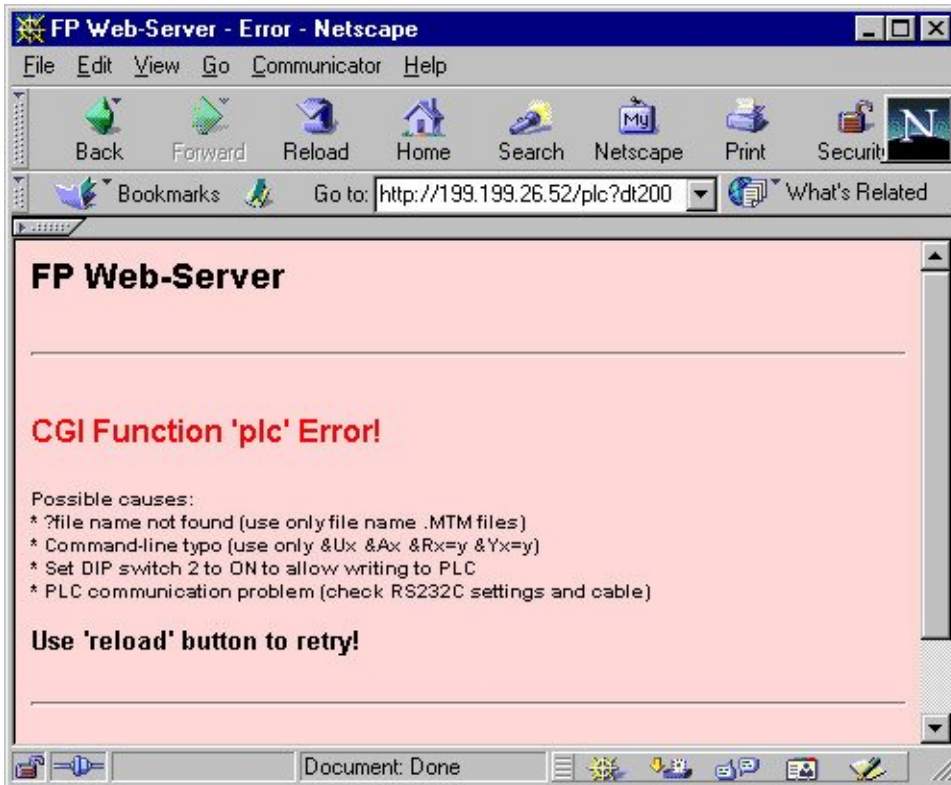

### 7.1.9 Using Variable Names Instead of Absolute PLC Addresses

The data type and address part **TTxxxy** of a PLC data display or input field can be replaced by the corresponding variable name from the FPWIN Pro project, e.g. **{'VarName' \_aa \_bb}**.

During the compilation and the transfer of the HTML page the variable name is replaced by the absolute, global PLC address found in the CSV file. The CSV file is exported by FPWIN Pro and stored in the Configurator project folder. There is only one CSV file allowed in the Configurator project folder. The CSV file can have any name - but it must have the CSV extension (CSV file type).

For variable names please use numbers from 0 to 9, letters from A to Z and the underscore only! Please do not use special characters like \* - < > \$ % / & and so on! Upper and lower case letters have the same meaning. For example 'VarNam' is the same as 'varnam' or 'VARNAM'.

In the following example based on "Example4" the FPWIN Pro project with the following global variable list is used:

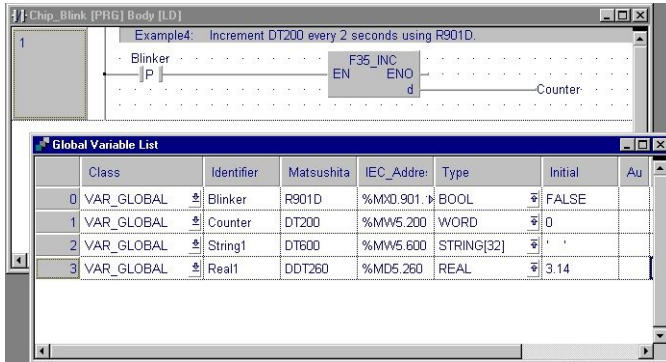

Carry out the following steps in FPWIN Pro to export the global variable list as a CSV file:

### Generating a CSV File



#### PROCEDURE

1. Use the menu items "Extras -> Export CSV File..."
2. Select the folder where the Configurator project is stored

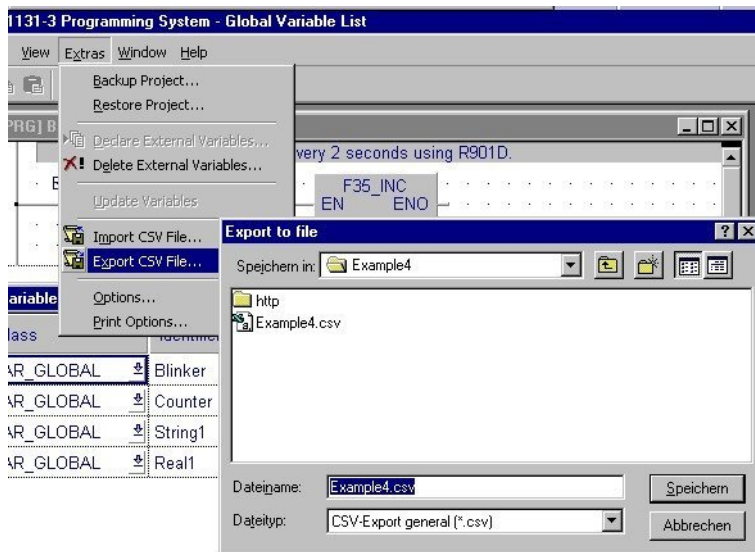

The settings in the following dialog "CSV-Export general" need not be changed

**3. Save the CSV file by clicking on [Export]**

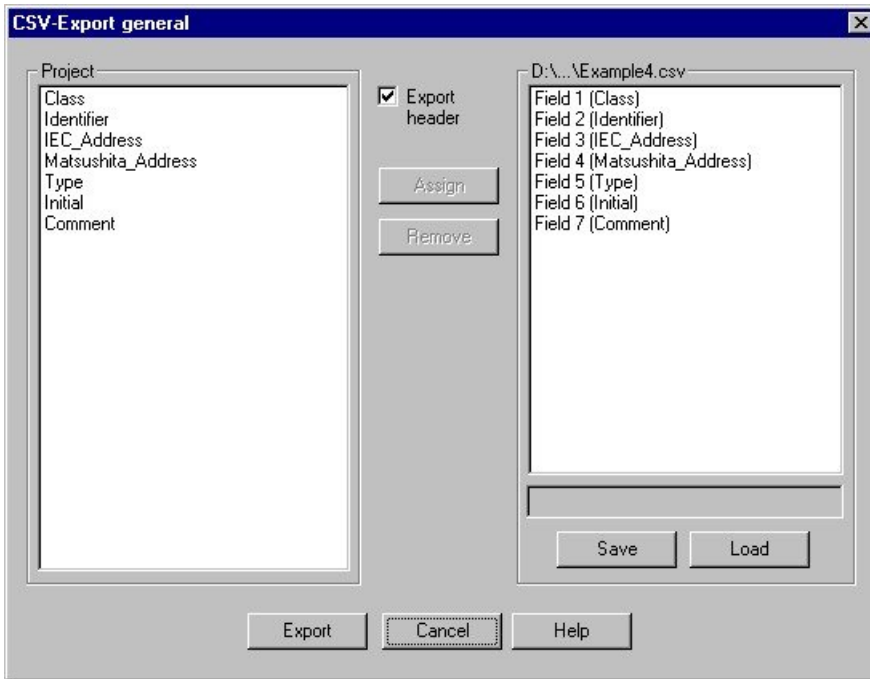

These steps have generated a CSV file in the Configurator project folder

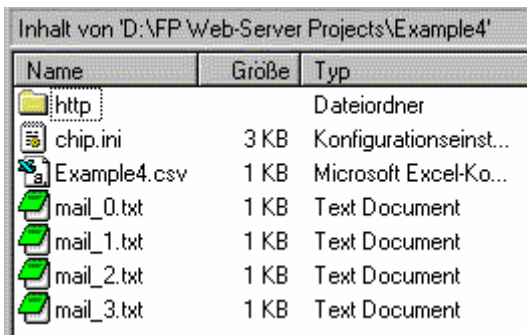

If a text editor is used the contents of the CSV file looks like this:

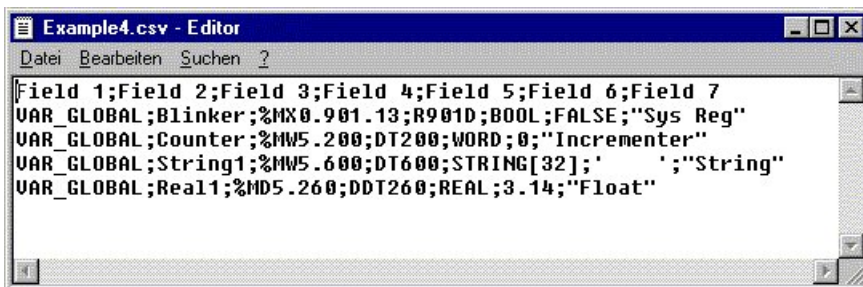

**Accessing a CSV File via an HTML Page**



**PROCEDURE**

- 1. If a Configurator project also has a FPWIN Pro CSV file, the PLC addresses in a HTML page can be referenced by its (global) variable name**

In the HTML editor the use of these variable names instead of absolute address values can look as follows:

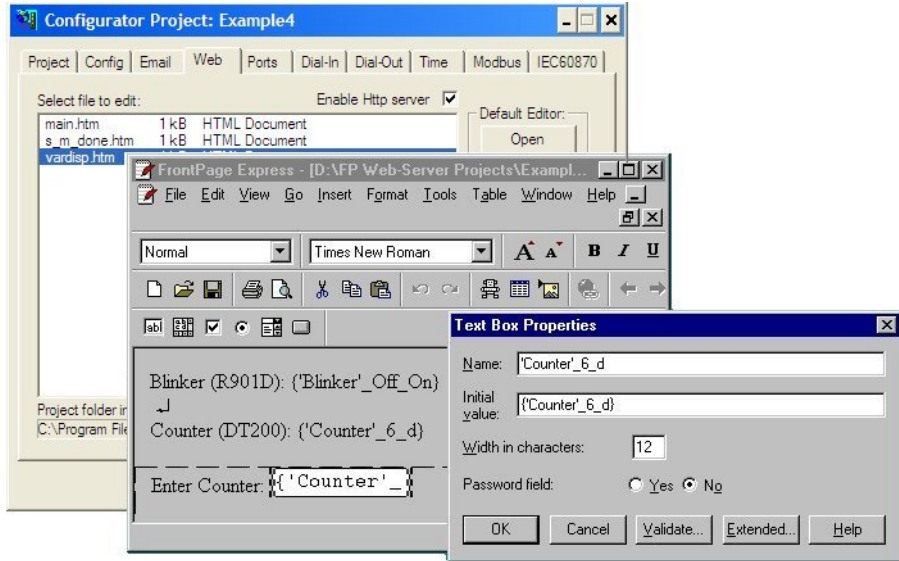

- 2. If this HTML page is now downloaded to the FP Web-Server the variable names are replaced by the absolute PLC addresses found in the CSV file**

Looking at the example above, with the browser it should look as follows:





## 7.1.10 Access Protection for Individual HTML Pages

With the FP Web-Server, Password protection for ALL HTML pages containing PLC data can be switched on or off.

To protect individual pages only, enter the **{PW}** command in the HTML code. The text **{PW}** is no longer displayed on the browser after sending the page using [SEND] to the FP Web-Server.

Three variations are possible:

1. **Default password:**

{PW} protects the page by user name and password

2. **Individual password:**

With the marker **{PW\_pppp}** set in the HTML code, the user name specified in the base configuration and the password **pppp** of the new command will be asked for before displaying the data. Hence you can assign different passwords to different HTML pages.

3. **IP lock security:**

The tag **{PW\_ip.ip.ip.ip}** enables only the computer with the IP address **ip.ip.ip.ip** to display the page, hence enabling designated computers to display certain HTML pages. The enabled IP address "ip.ip.ip.ip" can be a single address such as 192.168.200.55 or it can define an address range by using asterisks (\*). For example, the tag **{PW\_192.168.200.\*}** allows clients with an IP address from 192.168.200.1 to 192.168.200.254 to access the protected HTML page.

If the computer has the wrong IP address, the following standard dialog is displayed by the browser:



However, the FP Web-Server will not accept any entry.

The individual page protection should be switched ON in the configuration.

### 7.1.11 Inputs for Controlling PLC internal relays on HTML Pages

To control PLC internal relays via HTML pages, hyperlinks, as they are described under Calling Parameters (see page 73), are used. In the example projects you can find "links" for controlling in the DT200.HTM and MENT.HTM pages:

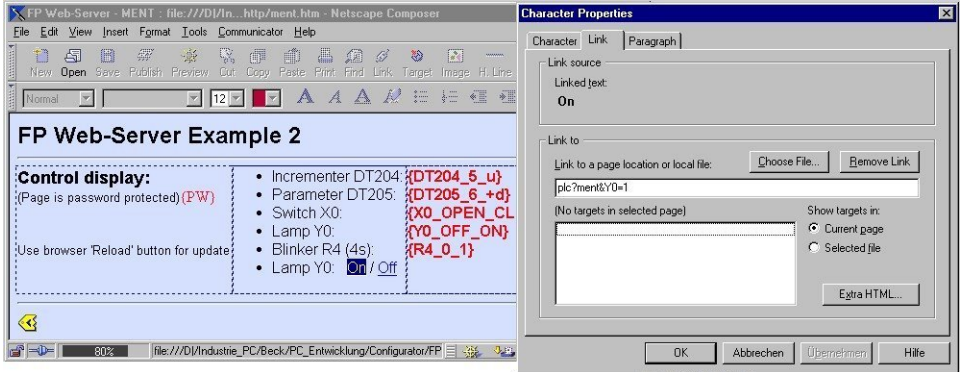

### 7.1.12 Defining Input Fields for PLC Data on HTML Pages

HTML [SUBMIT] fields are used to integrate PLC data input fields into an HTML page. The same PLC data field definition as for the display field is used, except for the curly brackets. Make sure that the definition is entered in the "Name" field.

An example thereto can be found in the online help of the configurator projects "Example2" and "Example13".

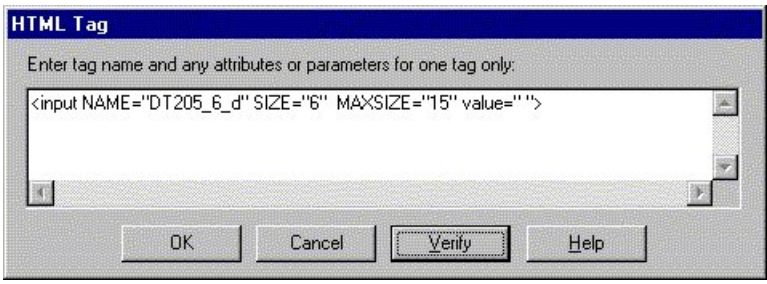

It is also possible to use a PLC display field to obtain an editable pre-allocation of the input field.

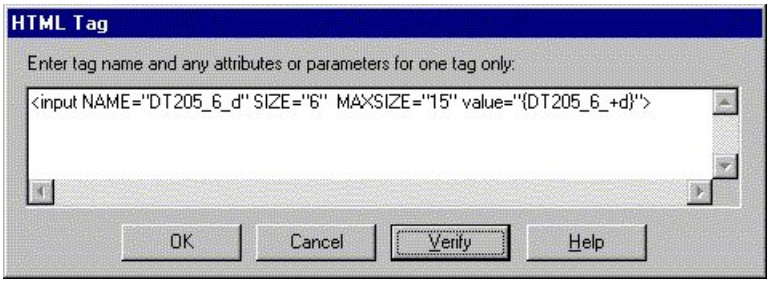

This has to be interpreted as follows:

<b>VALUE="{DT205_6_+d}"</b>	DT205 is read out of the PLC and interpreted as a signed decimal number and displayed in the input field with the algebraic sign. After that, the input editor is started in the HTML page.
<b>NAME="DT205_6_d"</b>	If the input editor is ended with <ENTER> or [SUBMIT], the input field is interpreted as a signed decimal number with 6 positions and saved as DT205 on the PLC.

The setup of the format specification for numbers is comparable to the format (see page 77) of the input fields. The data type and address part **TTxxxy** can be replaced by the corresponding variable name from the FPWIN Pro project, e.g. **{'VarName'\_aa\_bb}** or **{'name'\_5\_i}**. For details refer to Variable Names (see page 82).

A little browser window is generated after the input and the transmission of the data to the PLC, either to indicate a possible error message or a successful transmission:

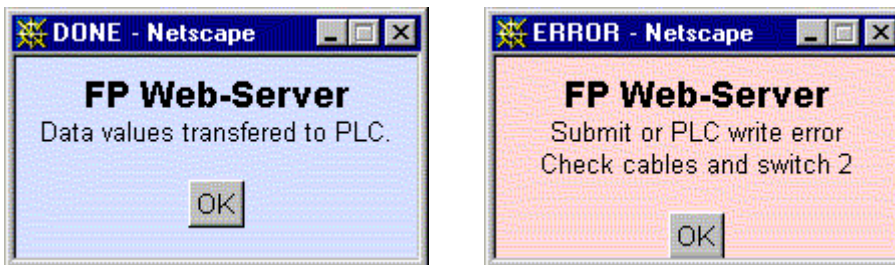

For the information to disable this window refer to automatic page reload after submitting PLC data (see page 94).

If an error occurs, the PLC address range may be limited with [Add. Range].

In general, there are two ways of defining an input field:

#### A) Send Input with Button:

Several input fields can be summed up in one 'input field' and sent to the PLC with a separately defined button. A confirmation dialogue box (OK or ERROR) is generated. In the following HTML code, the current value of DT204 is written into the first input field before and after the input editor is started. The inputs for DT204 and DT205 can be edited and then sent to the PLC by clicking [SET]. The input for DT204 is interpreted as an unsigned decimal number. The input for DT205 is interpreted as a signed decimal number (The <ENTER> key has no function here.):

```
<form ACTION="/plcpost" METHOD="POST" TARGET="SUBWIN" ONSUBMIT="opensubwin(200,100);">
<p>Enter DT204 <input NAME="DT204_5_u" SIZE="6" VALUE="{DT204_5_u}">
and DT205 <input NAME="DT205_6_d" SIZE="6" VALUE="">
and <input TYPE="submit" NAME="Button" VALUE=" set "></p>
</form>
```

#### B) Send Input with <ENTER> Key:

A single input field (It is also possible to use several input fields in one HTML page!) does not necessarily need a button of its own; it can be sent to the PLC immediately by pressing <ENTER>. A confirmation dialog box (OK or ERROR) is generated. In the following HTML code, the current value of DT260 is displayed in the input fields initially; after that the input editor is started. The input can be edited and then sent to the PLC by pressing <Enter>. The input is interpreted as a 32-bit floating point number:

```
<form ACTION="/plcpost" METHOD="POST" TARGET="SUBWIN" ONSUBMIT="opensubwin(200,100);">
<p>Enter DT260 <input NAME="DT260_12_f" SIZE="13" VALUE="{DT260_12_g}"> </p>
</form>
```

The individual HTML commands can be entered (exactly as described above) into the HTML code of the page and then adjusted respectively. Some HTML editors provide additional help and automatic generation for creating submit fields. The commands have the following significance:

<code>ACTION= "/plcpost "</code>	Enter precisely like this. CGI function of the FP Web-Server.
<code>METHOD= "POST "</code>	Enter precisely like this. Method of the CGI call.
<code>TARGET= "SUBWIN "</code>	Enter precisely like this. Display the result in a separate window.
<code>ONSUBMIT= "opensubwin(200,100) "</code>	Enter precisely like this. Java Script call and window size.
Enter DT204	Variable text will be displayed as seen.
<code>NAME= "DT204_5_u "</code>	Specification of the memory address in the PLC and interpretation of the input format.
<code>SIZE= "6 "</code>	Width of the input window in number of characters.
<code>VALUE= "{DT204_5_u} "</code>	Initial value of the input field. Pre-allocation of the Edit field.

Only for the definition of buttons in case A):

<code>TYPE= "submit "</code>	Enter precisely like this. Function of the [SUBMIT] buttons.
<code>NAME= "Button "</code>	Enter precisely like this. Name of the [SUBMIT] button.
<code>VALUE= " set "</code>	Variable labeling of the [SUBMIT] buttons.

### 7.1.12.1 Examples on PLC Data Entries via HTML Page

a) Decimal numbers

Entry format	User entry	Data in PLC register
DT201_16_u	12	DT201= 12 (0C hex)
DT201_16_d	-32768	DT201= -32768 (8000hex)
DT202_16_ld	1234567	DDT202=1234567 (12D687hex)
DT202_16_f	123.4	DDT202=123.4 (42F6CCCD hex)
DT202_16_f	1.2e4	DDT202=12000 (463B8000 hex)

b) Strings

Entry format	User entry	Data in PLC register
DT602_16_S	1234	DT602-DT603="1234"
DT602_16_S	123	DT602-DT603="123?" (? is unchanged)
DT600_16_s	1234	DT601=4 DT602-DT603="1234" (DT600 > 3)
DT602_16_c	ABC	DT602="A?" (? is unchanged)

c) Hex entries:

In the latest version also the format type characters 'x' and 'X' are allowed for hexadecimal PLC data entries. Hex data entries are possible for 16-bit (name="DT200\_6\_X") and 32-bit (name="DT300\_16\_lx") PLC data registers:

Entry format	User entry	Data in PLC register
DT201_16_X	7b	DT201= 123 (007B hex)

Entry format	User entry	Data in PLC register
DT201_16_X	8000	DT201= -32768 (8000 hex)
DT202_16_lx	01E240	DDT202= 123456 (0001E240 hex)

Complete example to enter a 16-bit hex value for DT210:  
 <form action="/plcpost" method="POST" target="SUBWIN"  
 onsubmit="opensubwin(200,100);">  
 Enter DT210 <input SIZE="6" name="DT210\_6\_X"> in hex</form>

d) Format specification for integer values

With the latest version the 'precision' (range 1...9) format specification for integer values is also valid for PLC data entry via the HTML submit function. It is now possible to enter a floating-point value with a decimal point, which is stored as a 16-bit or 32-bit integer in the PLC data register. Examples for entering integers with a decimal point:

Entry format	User entry	Data in PLC register
DT201_6_.2d	12.3	DT201= 1230 (04CE hex)
DT201_6_.2i	-1	DT201= -100 (FF9C hex)
DT201_6_.1u	12.345	DT201= 123 (007B hex)
DT201_16_.5li	123.4567	DDT201=12345670 (00BC6146 hex)

**Further examples:**

More PLC data entry examples can be found in "Example2" and "Example13".

**7.1.12.2 Notes on Strings**



**NOTES**

- The format definition **S** is used for ASCII strings without "header", i.e. an ASCII string is generated with the F95 command in the PLC. The length that was determined in the input field definition is the maximum string length that can be transferred to the PLC. It can be shortened even further with the format command **.xS**. In this case **x** stands for the number of characters of the shortened string length.
  - **NULL-String**: If such a string has the length 0 (zero) the data in the PLC is not changed.
- The format definition **s** is used for ASCII strings with "header", i.e. ASCII strings that have been generated with the string commands of FPWIN Pro (from version 3.0 on) in the PLC. The "header" consists of two 16-bit words before the real ASCII string.
  - 1st Word: Maximum string length permitted that can be saved here. Zero disables writing.
  - 2nd Word: Current length of the strings.
  - 3rd Word and following: ASCII characters of the string in LO/ HI sequence in the word.
  - Firstly, the entered string will always be shortened to the length that is depicted in

the SIZE="x" command. Secondly, this string can be shortened even further with the format command .xs. Thirdly, the maximum memory permitted (Header 1st Word) has to be taken into account. After the transmission of the string to the PLC, the "header" (2nd Word) with the new length will be updated.

- **Un-initialized String:** If a string variable is not initialized by the FPWIN Pro project, the 1st Word (maximum string length) is zero. With this the FP Web-Server cannot store any character in this string because no memory is reserved for storing!
- **Null-String:** If such a string has the length 0 (zero) the current length of the string (2nd Word) is also set to 0, i.e. the string is deleted.
- **A string (s or S) of an input field (determined by MEWTOCOL) can only be 48 characters long! Compare to display fields for strings that are 52 characters long!**
- **The special characters < and > are transcribed as ¼ and ¾ characters when the strings are displayed. If the special characters ¼ and ¾ are used in input fields, they will be transcribed into the characters < and > before they are transmitted to the PLC.**
- **Only 7-bit ASCII characters (see page 99) are supported when strings are displayed or entered in HTML.**

### 7.1.12.3 Comments on Defining Input Fields for PLC Data on HTML

- In the current version only DT, FL and LD values can be defined in input fields. The input of internal relay values (R, Y) has to be realized via hyperlinks in the format, as it is described under Calling Parameter (see page 73).
- In the definition of the input field NAME="DT205\_6\_d", only numbers from 0 to 9, letters from A to Z and the underscore are permitted! Please do not use special characters like \* - < > \$ % / ' & and so on!
- The data type and address part **TTxxxY** can be replaced by the corresponding variable name (see page 82) from the FPWIN Pro project, e.g. **{'VarName'\_aa\_bb}** or **{'name'\_5\_i}**.
- In the current version, octal numbers cannot be entered, i.e. format specifier **\_o** has not been implemented yet!
- The "default" MEWTOCOL address of the PLC cannot be modified by the calling parameter "Address Modifier" **&A=x** for input fields!
- In case "A) Send Input with Button" where several input fields can be sent to the PLC with a button, the maximum number of characters of all NAME="..." commands is limited to 300. The number of characters of all VALUE="..." commands is limited to 300 as well.
- You can limit the PLC write access with the function [Add. Range].

For programming examples in C++ and Java to send PLC data via http submit function to the PLC refer to the online help under the keyword "Appendix K) Programming Samples: Access to the FP Web-Server / PLC via TCP".

### 7.1.13 Example on Formatting Display and Input Fields

The file TEST.HTM of the "Example2" project shows a multitude of formatting methods:

TEST.HTM: In the HTML Editor:

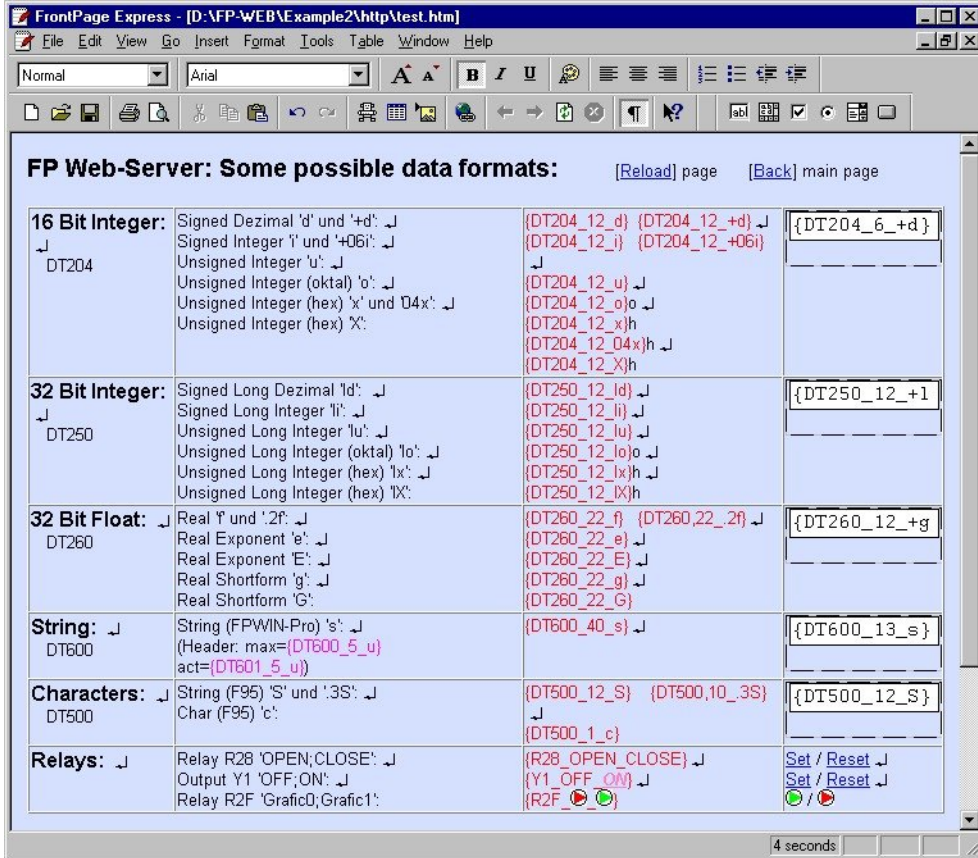

Input Fields in the HTML Editor:

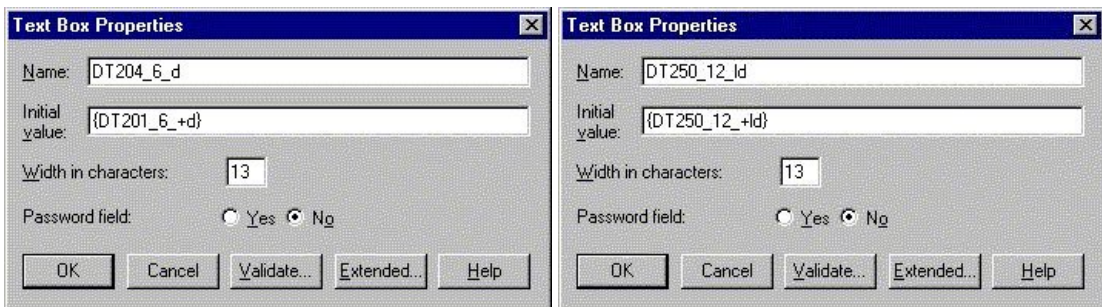

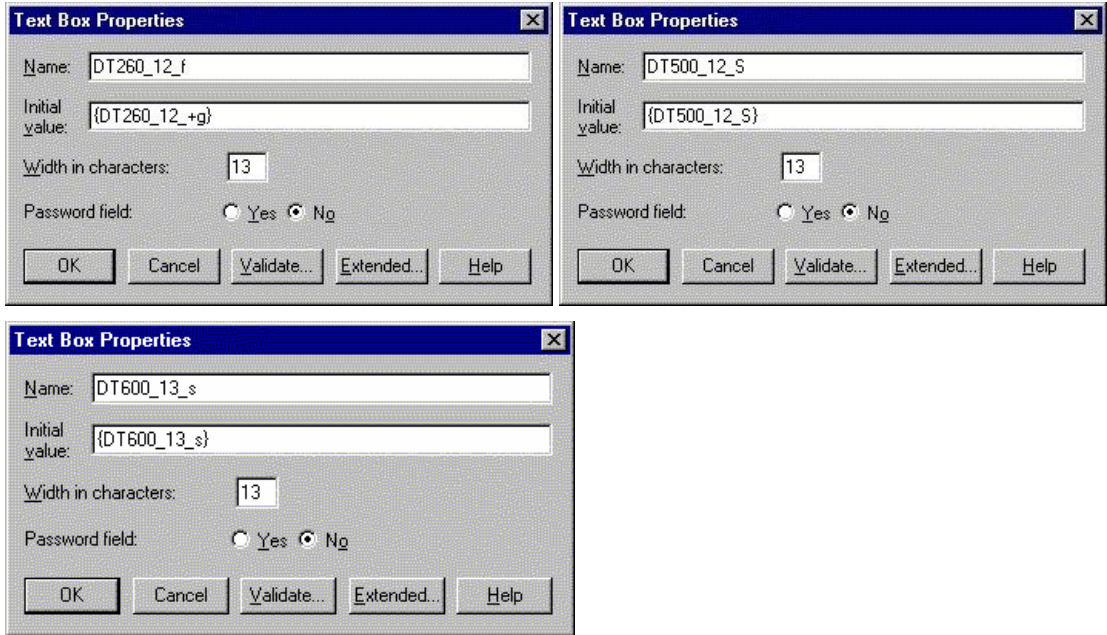

TEST.HTM: Displayed in the Browser:

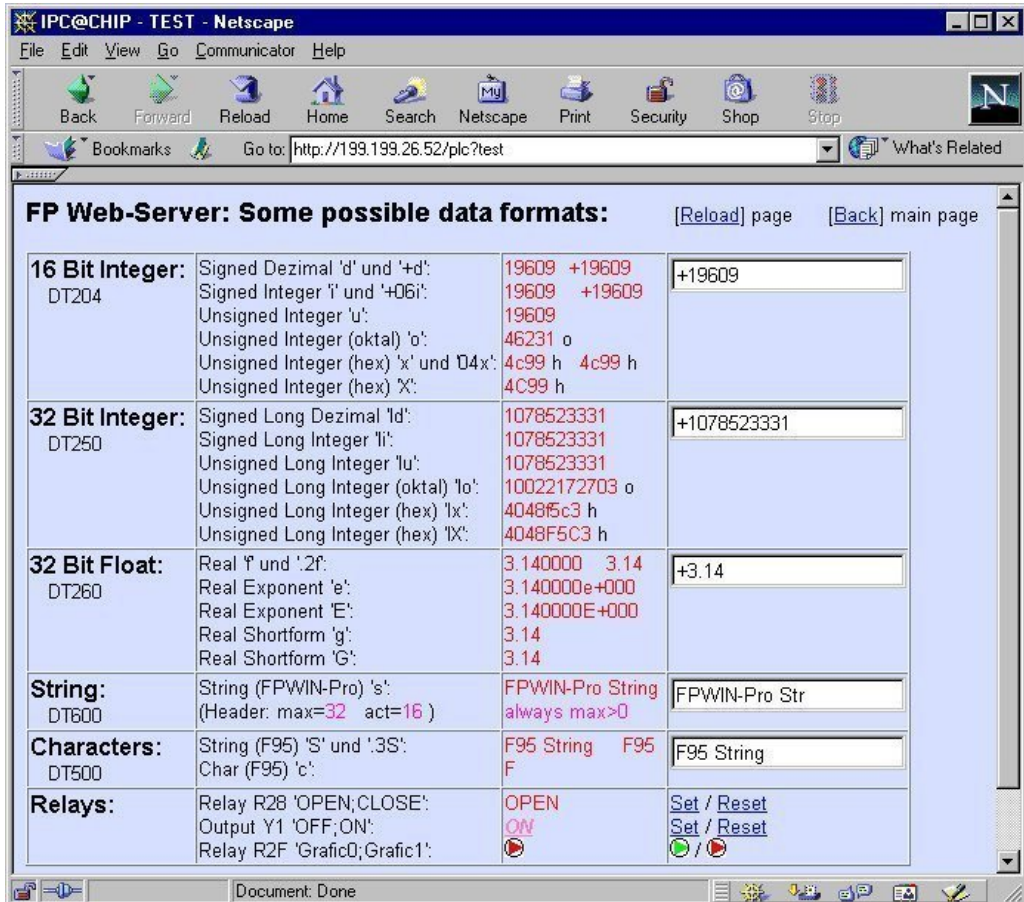



Please note that the string at DT600 needs to be initialized by the PLC program before data can be stored there. Also see second note in "Notes on Strings", Defining Input Fields for PLC Data on HTML Pages (see "Defining Input Fields for PLC Data on HTML Pages" on page 87).

### 7.1.14 Automatic Page Reload upon Submitting PLC Data

If the html file "s\_m\_done.htm" is uploaded to the FP Web-Server **before you start the unit**; the html code of this file will be reloaded to the browser after submitting PLC data. The following default window will be replaced by displaying the file "s\_m\_done.htm".



#### Example 1: Automatic refresh of an html page after sending PLC data

Enter the following lines in the file "s\_m\_done.htm":

```
<html><head><title>DONE</title></head><body>
<script language="JavaScript">
opener.location.reload(true);
window.close();
</script></body></html>
```

#### Comments:

- This script also automatically closes the default window OK or DONE
- Find a copy of this file in \\Example4\http in your installation directory
- Using this file you can execute Java Script applications after sending PLC data
- The file "s\_m\_done.htm" may not contain PLC data fields, e.g. {DT100\_6\_d}
- **Restart** the IEC Configurator after you have modified the file "s\_m\_done.htm". (When modifying other htm files the unit does not have to be restarted.)

#### Example 2: Automatic refresh of an html page after sending PLC data but without closing the OK window automatically

Using this script you have to click [OK] to close the OK window

```
<html><head><title>DONE</title></head><body>
<p align="center"><font face="Arial"><strong><big>FP
Web-Server</big><br>
</strong><small>Data values transfered to PLC.</small></font></p>
<form><div align="center"><center><p>
<input type="button" value="OK" + " onClick="self.close()"></p>
</center></div></form>
```

```
<script language="JavaScript">
opener.location.reload(true);
</script></body></html>
```

This script cannot be used with all versions of MS Internet Explorer while some windows of html browsers are opened at the same time containing different data.

### Comment:

Thus beware when using advanced Java Script because different versions of browsers and/ or manufacturers may be incompatible.

## 7.1.15 Example on Java Script Automations

In the Configurator project "Example4" and "Example5" the usage of Java Script is demonstrated.

In the Configurator project "Example4" Java Script is used to generate a "line" in the HTML output with the number of dashes read from of PLC data DT200. The source in the HTML file looks as follows:

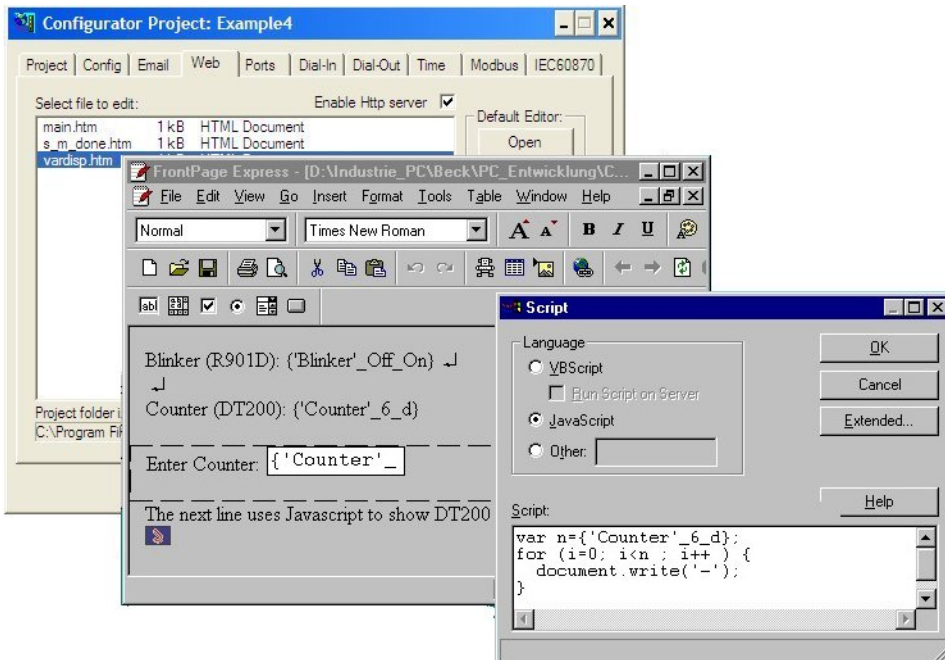

In this example DT200 (variable name "Counter") is read from the PLC and interpreted as number 'n'. In a loop that follows, 'n' dashes '-' are output. The resulting HTML page looks as follows:

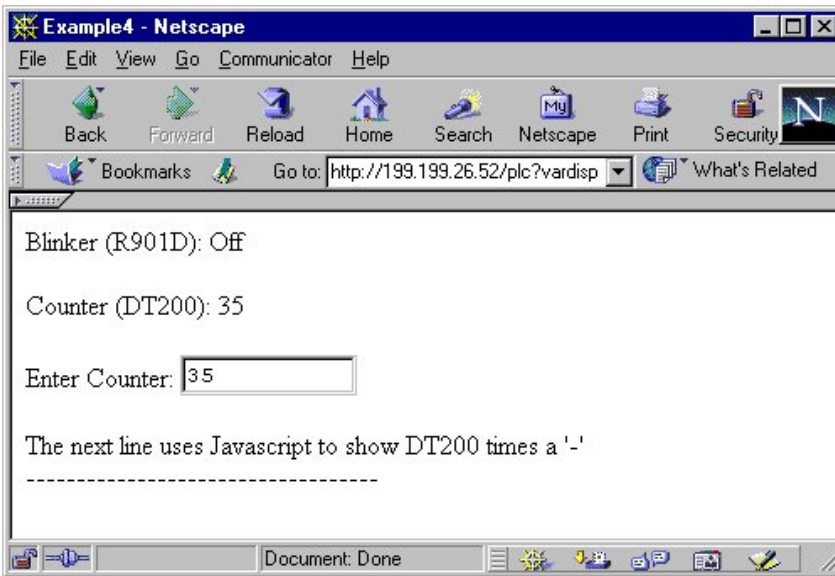

#### ◆ NOTE

**The character { in Java Script must be followed by a space character, tab character or a new line. Otherwise it is interpreted as a PLC data field.**

#### Example:

```
for (i=0; i<n ; i++ ) {document.write('-'); }
will generate a compiler error. But the following code will work as expected:
for (i=0; i<n ; i++ ) {
  document.write('-');
}
```

### 7.1.16 Notes on HTML Frames

---

In the following file "MAIN.HTM" of "Example8" two frames are used.

```
<html>
<head>
  <title>FP-WebServer Example8 - Frames</title>
</head>
<frameset rows="50%,50%" frameborder="yes" border="1" framespacing="1">
  <frame name="topFrame" src="plc?top&U=1" scrolling="auto">
  <frame name="untenFrame" src="plc?unten" scrolling="auto">
  <noframes>
    <body text="#000000" bgcolor="#FFFFFF">
    </body>
  </noframes>
</frameset>
</html>
```

The content of each frame is stored in a separate HTML file:

TOP.HTM

UNTEN.HTM

Each HTML file can be edited separately. Both HTM files show PLC data but the TOP.htm site is automatically updated every second.

### 7.1.17 Notes on XML Files with PLC Data

---

#### The FP Web-Server can deliver XML files

The FP Web-Server's http server can also deliver PLC data within XML files. Similar to an HTML file, the XML file can include the special PLC data tag (see "Data Fields for Displaying PLC Data on HTML Pages" on page 77) {Ttxxxxy\_aa\_bb}. This tag is replaced by the actual PLC data at the time the XML file is requested (see page 73) from a client in the form "http://199.199.26.52/plc?filename.xml"

#### General XML Info

The XML file format is a sort of ASCII text file designed for data exchange (data import/export, data base interface ...). An XML file contains only structured data and not style or format information.

The XML file format is a sort of ASCII text file designed for data exchange (data import/export, data base interface ...). An XML file contains only structured data and not style or format information. An XSL file with style and format information is needed to transform an XML into a different file (display) format. The "transformNode()" function of the Microsoft Internet Explorer is used to take the XML data and an XSL format definition to generate an HTML page.

The XML / XSL conversion is demonstrated in "Example14".

XML file handling is carried out in four steps (based on "Example14"):

1. For example, the user generated XML file (including PLC data tags) "Producn.xml" may look like:

```
<?xml version="1.0" encoding="ISO8859-1"?>
<Production xmlns:xsi="http://www.w3.org/2001/XMLSchema-Instance">
  <Unit>
    <Type>{DT10_10_s}</Type>
    <Produced>{DT18_6_u}</Produced>
    <Rejected>{DT19_6_u}</Rejected>
    <State>{R11_off_on}</State>
  </Unit>
</Production>
```

2. The XML file "Producn.xml" is transferred to the FP Web-Server unit via the FP Web-Configurator Tool. In this example we use an FP Web-Server unit with the IP address 199.199.26.52.
3. A TCP client can request the FP Web-Server unit's http server to deliver the XML file "Producn.xml" (including current PLC data), which takes on the form:  
http://199.199.26.52/plc?Producn.xml

This file can be read by an Internet browser or a user application program.

4. The client will receive the following resulting XML file, for example:

```
<?xml version="1.0" encoding="ISO8859-1"?>
<Production xmlns:xsi="http://www.w3.org/2001/XMLSchema-Instance">
  <Unit>
    <Type>Standard </Type>
    <Produced>332 </Produced>
    <Rejected>54 </Rejected>
    <State>off</State>
  </Unit>
</Production>
```

In this example the following PLC data was currently available on the PLC:

```
String at DT10 = "Standard"
Integer value at DT18 = 332"
Integer value at DT19 = 54"
Internal relay R11 state = false
```

For programming examples in C++ and Java to read an XML file from the FP Web-Server refer to the online help under the keyword "Appendix K) Programming Samples: Access to the FP Web-Server / PLC via TCP".

### 7.1.18 ASCII Character Codes for Strings

Only 7 bit ASCII character codes are supported when strings are displayed or entered in HTML.

Dec	Hex	Char	Dec	Hex	Char	Dec	Hex	Char
32	20	sp	64	40	@	96	60	`
33	21	!	65	41	A	97	61	a
34	22	"	66	42	B	98	62	b
35	23	#	67	43	C	99	63	c
36	24	\$	68	44	D	100	64	d
37	25	%	69	45	E	101	65	e
38	26	&	70	46	F	102	66	f
39	27	'	71	47	G	103	67	g
40	28	(	72	48	H	104	68	h
41	29	)	73	49	I	105	69	i
42	2A	*	74	4A	J	106	6A	j
43	2B	+	75	4B	K	107	6B	k
44	2C	,	76	4C	L	108	6C	l
45	2D	-	77	4D	M	109	6D	m
46	2E	.	78	4E	N	110	6E	n
47	2F	/	79	4F	O	111	6F	o
48	30	0	80	50	P	112	70	p
49	31	1	81	51	Q	113	71	q
50	32	2	82	52	R	114	72	r
51	33	3	83	53	S	115	73	s
52	34	4	84	54	T	116	74	t
53	35	5	85	55	U	117	75	u
54	36	6	86	56	V	118	76	v
55	37	7	87	57	W	119	77	w
56	38	8	88	58	X	120	78	x
57	39	9	89	59	Y	121	79	y
58	3A	:	90	5A	Z	122	7A	z
59	3B	;	91	5B	[	123	7B	{
60	3C	<	92	5C	\	124	7C	
61	3D	=	93	5D	]	125	7D	}
62	3E	>	94	5E	^	126	7E	~
63	3F	?	95	5F	_	127	7F	

## 7.2 Configurator Http Administration and Functions

The FP Web-Server unit's http server can be enabled or disabled. If enabled, you can handle Web files with this dialog.

All Web pages for the FP Web-Server are created and/or edited on the computer. To do this, it is best to select the respective file of the project in the Configurator's "Web" screen and start the preinstalled editor of the operating system by double-clicking (or choosing <Enter> or [OPEN]).

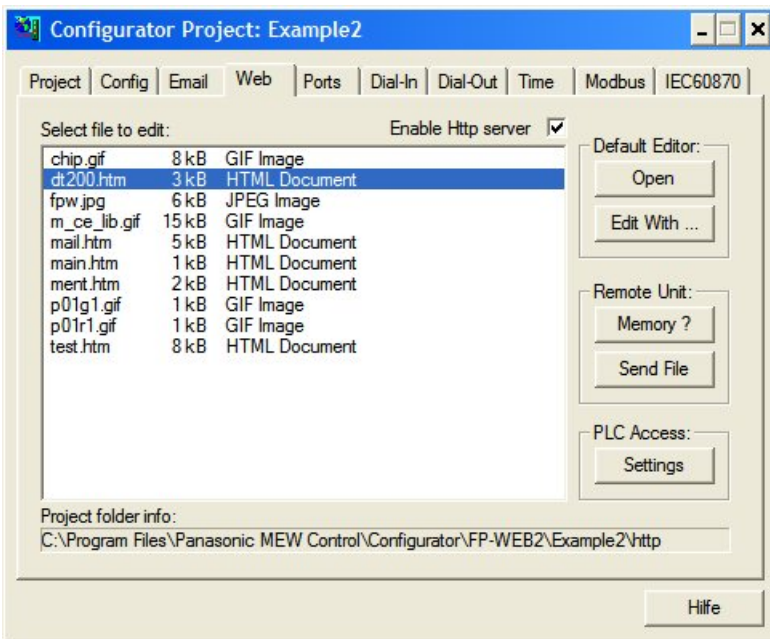

After double-clicking, the file name extension (type) is analyzed and the computer tries to find an installed program in the registry that can open and edit that type of file. If no such program is installed on the computer, you will receive an error message:

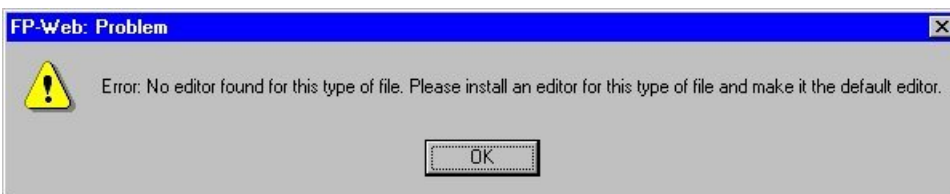

Alternatively you can select an installed editor by pressing [EDIT WITH]. The editor can be an HTML editor or a standard ASCII text editor.

We recommend installing the following programs and defining them as "default" for this type of file:

.HTM	Netscape Composer (is installed automatically with the Netscape Browser)
.GIF .JPG	PhotoEdit (can be installed with MS Office)

If the Microsoft Internet Explorer browser is used, the editor "Frontpage Express" has to be installed separately. See "Custom Install" during IE installation.

To test which editor is installed, click (while in Windows Explorer) on an .HTM file and use the right mouse button to call up a list of available editors.



## ◆ NOTES

---

- **If spaces or Japanese characters are used, an error message pops up before transmission to the FP Web-Server.**
- **All file names have to correspond to the DOS 8.3 format, i.e. the name may only have up to 8 characters and the extension (type) only up to 3 characters after the period. (For FP-WEB2, (see page 15) you can use long file names without special characters.)**
- **Recommended are Netscape Navigator version 4.7, 4.75 or 7.0, Internet Explorer version 5.0, 5.1 or 6.0 or Opera 7.03 or 7.50. Other versions have not been tested and should not be used.**
- **The file size displayed shows not the exactly value because it is rounded to whole KB.**
- **System, hidden and scc files are ignored by the Web file functions and not displayed in the list.**
- **Press <F5> to reload and refresh the file list display.**



## ◆ REFERENCE

---

For more detailed information, please refer to the online help under the following keywords: "Open file with default editor", "edit with an alternate editor", "available memory", "uploading the selected file to the remote unit", or "PLC access rights".





# Chapter 8

---

## Ethernet/ RS232C Ports

## 8.1 Generalities on the Ethernet/ RS232C Ports

---

The FP Web-Server can work as an Ethernet to a RS232C interface converter. Thereby all data the FP Web-Server receives via an Ethernet port (e.g. from a computer) are routed to its RS232C port and vice versa (i.e. all data received at the RS232C interface are sent back to the computer via the Ethernet). In this configuration the FP Web-Server is the server and the computer is the client.

To setup an FP Web-Server port as a client, refer to the online help under Enable Transparent TCP/IP Client Port. With two FP Web-Server units that are setup as a pair of transparent port server and client, two FP-Sigma can communicate with each other via PLC link function (PC link protocol) (take into account the timeout set in the PLC).

For a detailed description refer to the online help under the keyword "Configurator parameters to the MEWTOCOL port server" or "configurator parameters for the transparent port".

### 8.1.1 Server's Side

---

For this kind of data exchange, the FP Web-Server provides two special Ethernet (i.e. TCP/ IP) server ports that wait for an incoming connection from a client (e.g. a computer or an FP Web-Server configured as a port client):

#### a) MEWTOCOL Communication with the PLC

- 3-pin RS232C connection is connected with the PLC
- preset TCP/ IP port number 9094 (Server)
- up to three client connections are possible (TCP/ IP)
- MEWTOCOL protocol for data and program exchange

#### b) Transparent Communication

- 9-pin RS232C connection is connected with any unit (also PLC, GK panel...)
- preset TCP/ IP port number 9095 (Server or Client)
- only one client possible (TCP/ IP or UDP/ IP)
- arbitrary protocols (also MEWTOCOL) possible

#### Comments:

- If the PPP-Server or Internet email of the FP Web-Server is active and a modem is connected to the 9-pin RS232C, transparent communication is not possible because the 9-pin RS232C connector is busy.
- The current FP Web-Server firmware implementation supports up to 3 clients, i.e. up to three computers can communicate with a PLC! However, be aware that only one client is allowed to use the MEWTOCOL monitor commands! Standard MEWTOCOL commands and MEWTOCOL program download commands can be used by all three clients at the same time.  
This means that only one client is allowed to use FPWIN or PCWAY for data monitoring, but up to three GK panels can access the FP Web-Server at the same time because the

GK panels do not use MEWTOCOL monitor commands.

- To eliminate the problem of only one client being allowed to use FPWIN Pro or FPWIN GR for data monitoring, permit only one client. See the parameter MEWTOCOL Number of Clients.
- MEWTOCOL communication between a PLC and FPWIN Pro (or an FP Web-Server port client or GK panel) can involve a very high data load, i.e. with a single FPWIN Pro client, communication can be hindered so gravely that http pages and email communication are slowed down significantly.
- While MEWTOCOL multi-frame communication (program download) is being executed, MEWTOCOL communication for the other clients (including email and http functions) is temporarily stopped!

## 8.1.2 Client's Side

At the client's side (computer, GK panel or an FP Web port client) there are several possibilities and/or software packages to communicate with the FP Web-Server's MEWTOCOL server port (to exchange data with the PLC):

- With FPWIN Pro, GTWIN or PCWAY it is possible to communicate directly with the FP Web-Server, i.e. the PLC/ GT10 or GT30 via the Ethernet.

The following settings are required:

The screenshot shows the 'Communication Setting' dialog box with the following configuration:

- Network type: Ethernet
- Title: FPWEB
- Computer:
  - Acquire IP address automatically
  - IP address: 199, 199, 26, 178
  - Port No.: 1025 (0, 1025 - 32767)
  - Station No.: 64 (1 - 64)
- Destination:
  - IP address: 199, 199, 26, 52
  - Port No.: 9034 (1 - 32767)
  - Station No.: 1 (1 - 64)
- Communication Time-out (Sec): 10
- Connection Time-out (Sec): 60
- Use ET-LAN unit

Do not activate the check box "Use ET-LAN unit"!

- With GKWIN version 2.0 it is also possible for a GK panel (GK30 or higher with a built-in Ethernet card) to communicate directly with the FP Web-Server.

The following settings in GKWIN are required:

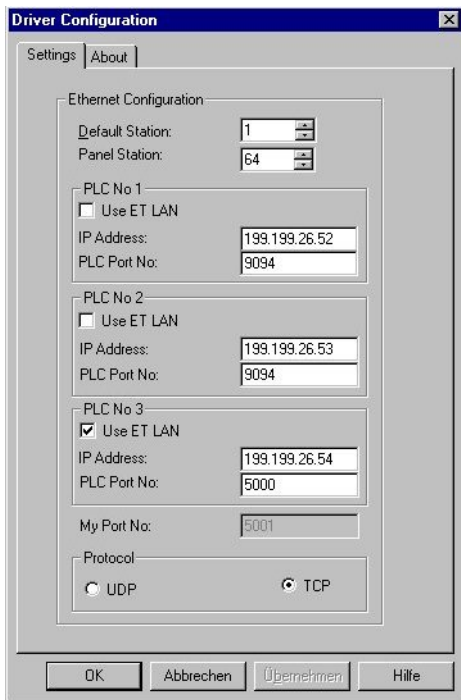

**Comments:**

If the FP Web-Server is connected, do not activate the check box "Use ET-LAN"! In the setup example above, only PLC No. 3 is an ET-LAN unit.

Any communication via Ethernet must be stopped before a new configuration is sent to the FP Web-Server. For example, the FPWIN Pro online mode must be ended before changing the configuration of the FP Web-Server. Terminate access to a GK panel before changing/updating the FP Web-Server configuration.

- c) Using a second FP Web-Server setup as transparent port client, RS232 communication via Ethernet can be established. Such a port client can be used for:

Programs (DOS programs) with no Ethernet support that use the RS232 port only

To upgrade any RS232 device with Ethernet connectivity, set up the transparent port as follows:

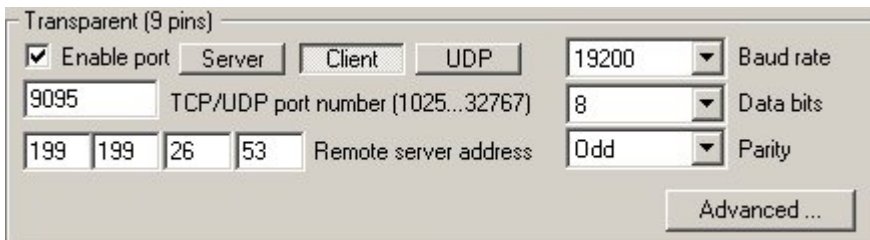

- d) Also the FP2 ET-LAN unit can communicate with the FP Web-Server ports. Using the ET1 library for FPWIN Pro makes PLC programming easy:

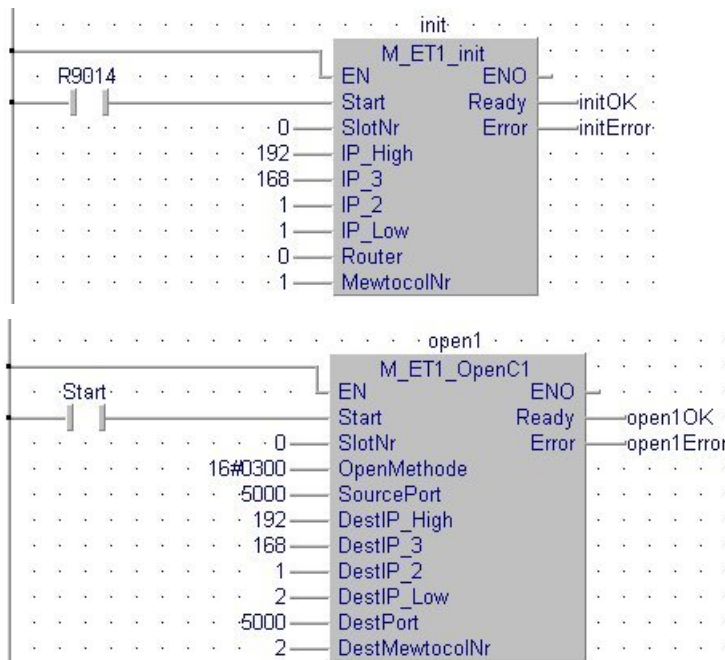

- e) Program your own MEWTOCOL client application:  
 For more information refer to the C++ and Java programming example in the online help under the keyword "A.) Client Programming Example to Access PLC Data (Via MEWTOCOL Server Port 9094)".
- f) PC COM Port Redirection for FP Web-Server Ports



## **Chapter 9**

---

# **Dial-In Setup for PPP-Server**



## 9.1 Dial-up Networking Setup for Computer/ FP Web-Server

---

The FP Web-Server can administer a modem that permits logging on a "PPP-Client" and establishing a TCP/ IP connection to the FP Web-Server via modem.

When the connection has been established, the functions are the same as the ones described above for Ethernet communication.

Functions possible:

- Http server for Web pages
- RS232C/ Ethernet ports
- Modbus communication
- Remote configuration

In addition, the FP Web-Server provides a "Gateway" function that allows other FP Web-Servers (that are connected to the "Gateway" FP Web-Server via the Ethernet) to be accessed via a long-distance modem connection. A description of the gateway setup can be found under PPP Gateway Functions (see page 119).

In the following paragraph, the installation of a Windows95 computer and modem is described. Using its standard Windows Dial-up Networking (PPP-Client) functions you can call up a FP Web-Server.

For a detailed description of the parameters for the PPP-Server in the FP Web-Server, refer to PPP-Server Configurator Inputs and Parameters (see page 127).



### ◆ NOTES

---

- **In a LAN, only one PPP server gateway is allowed.**
- **The default LAN gateway address is replaced by the PPP gateway address during a modem connection.**
- **Set up the PPP client to accept the remote IP address from the PPP server.**
- **Problems may occur if the server is connected to a client via modem and via LAN at the same time.**

### 9.1.1 TCP/ IP Network Installation of a Windows Client

---

To make it possible for a computer (FPWIN Pro, GKWIN, COM2WINSOCK, COMIP, etc.) to communicate with the FP Web-Server via the network, the TCP/ IP network protocol has to be installed. These settings are independent of the decision whether the communication is carried out via the Ethernet or via the dial-up networking modem. For details on the TCP/ IP installation on a Windows computer, please refer to the online help under TCP/ IP Setup for Configurator/ Browser Operations via LAN.

**Comment:**

The following screenshots were taken from a Windows 2000 operating system. The layout of other Windows operating systems may differ slightly.

**9.1.2 Modem and Dial-up Networking Installation of a Windows Client**

Configure and test the respective modem under "system settings", "modems". (For example, a "standard 28800 BPS modem" to COM 2 was used.) Do not forget to set the optional parameters correctly before closing "modem", "system settings".

**Comments:**

- We recommend the Panasonic FP MODEM-EU for our customers in Europe.
- The driver "MdmFPmodem.inf" for the FP MODEM-EU (now supports all versions of Windows NT) can be found on the Configurator setup CD in the folder: "Other-Tools/PPP\_Cable"
- For a null modem cable connection please find the necessary driver "mdmcisc2.inf" on the configurator setup CD in the folder: "Other-Tools/PPP\_Cable"

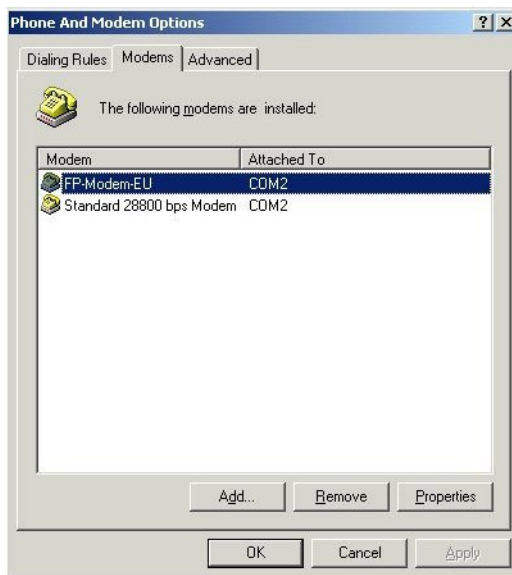
**PROCEDURE****1. Open the dialog "Phone and Modem Options"**

**2. Press [ADD] to add a new modem**

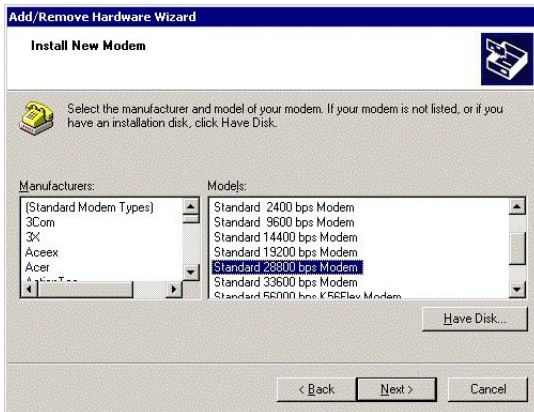
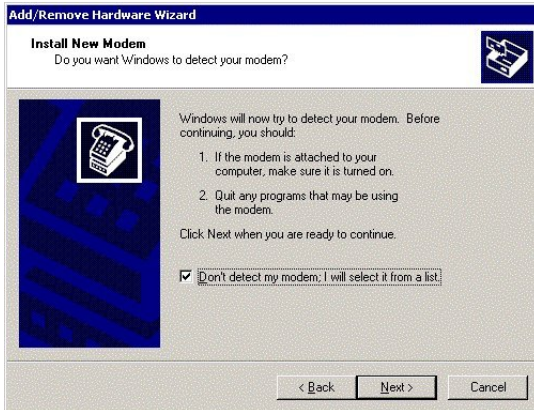

The modem used must support RTS/CTS flow control. Use command AT%K0&K3To enable this for the FP Modem-EU.

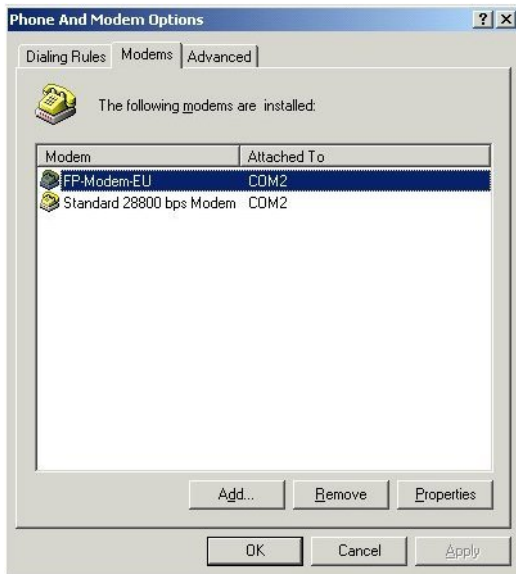

**3. Windows95: Install the dial-up networking and restart the computer**

In "system settings", "network", a dial-up networking adapter with TCP/ IP protocol (Optional: the client gets his address automatically from the server.) should be installed now. For details on the TCP/ IP installation on a Windows computer, refer to the online help under TCP/IP Setup: Configurator/Browser Operations Via LAN.

4. Double-click "Create New Connection" in the folder "Dial-up Networking" and create a new entry by entering the respective data

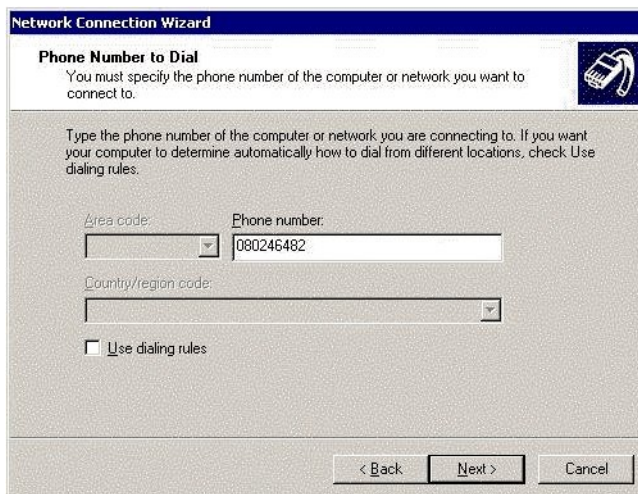
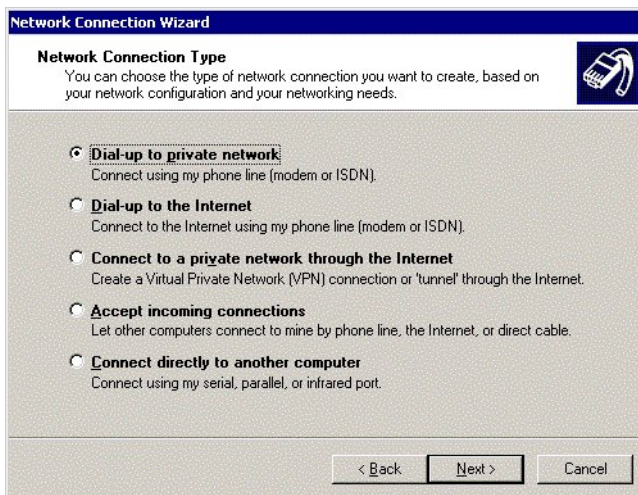
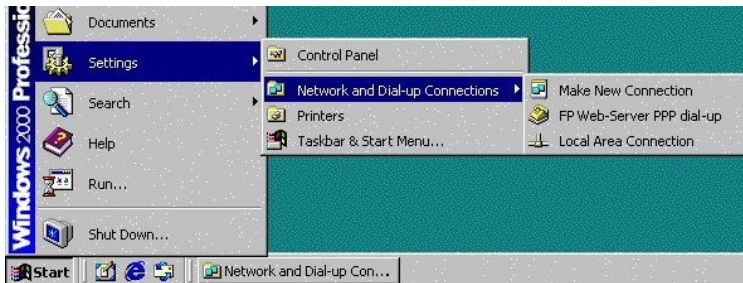

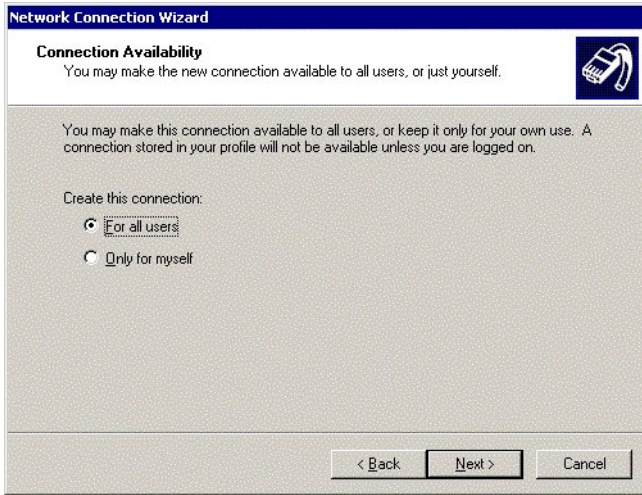

**5. After having completed the "New Entry", double-check the "Properties"**

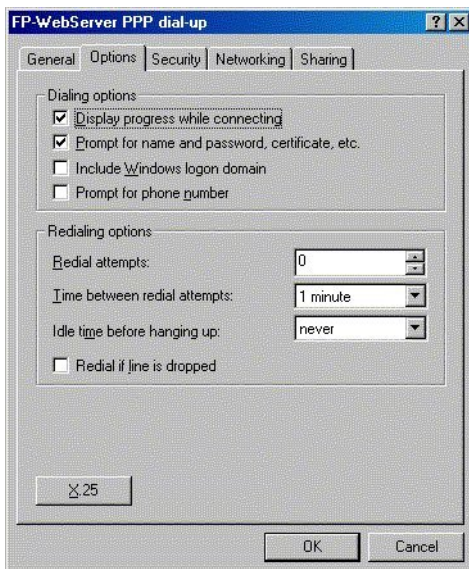
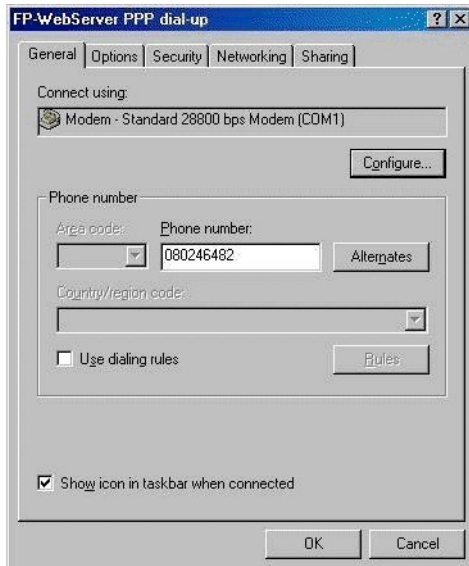

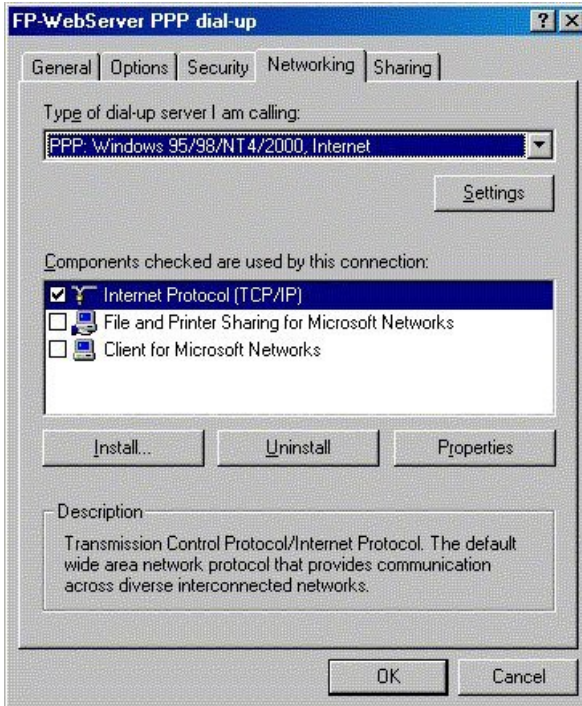
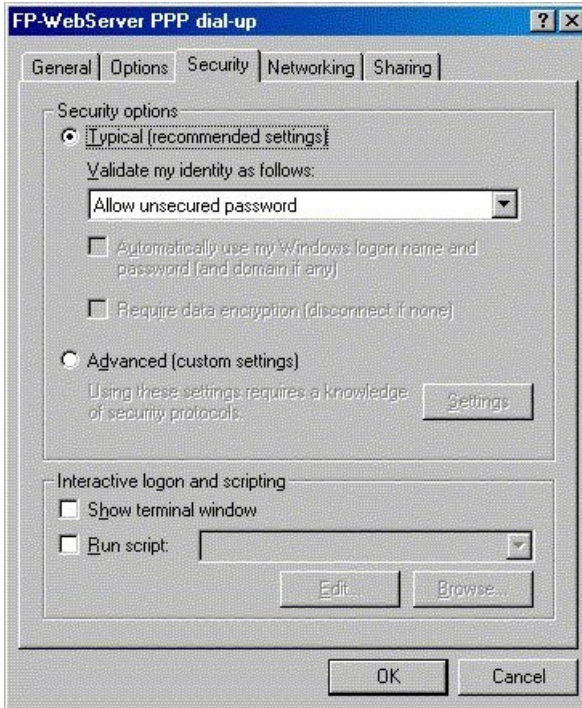

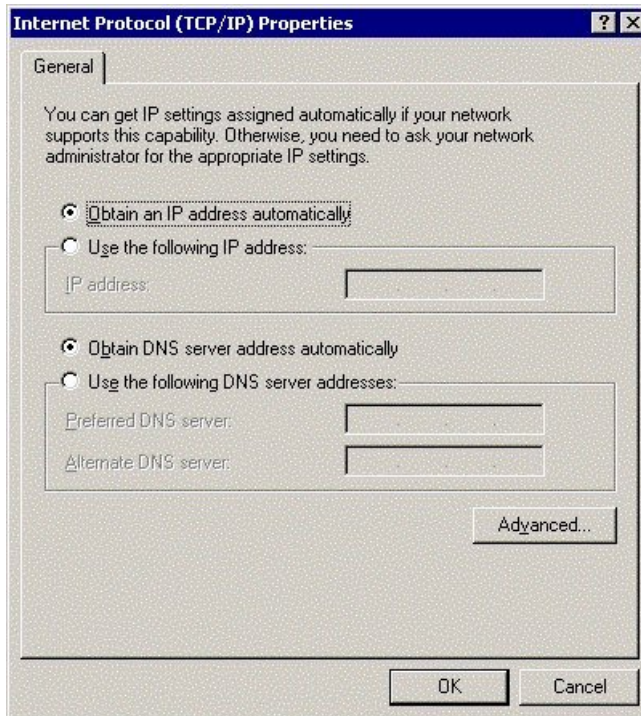

**6. Enter the password that was defined in the Configurator project before in lower case only**

For further information on passwords, please refer to Base Configuration/ User Name and Password and preinstalled passwords and safety instructions (see page 170).

**Example:**

Even if the password was "Abc1", it has to be entered as "abc1" for dial-up networking.



The Windows computer and the FP Web-Server should NOT be connected



additionally via Ethernet.

**7. As soon as the connection is established, the application that accesses the FP Web-Server (via TCP/ IP protocol) can be started**

The browser, Configurator, FPWIN Pro, etc. can be used in the same way as with an Ethernet connection.

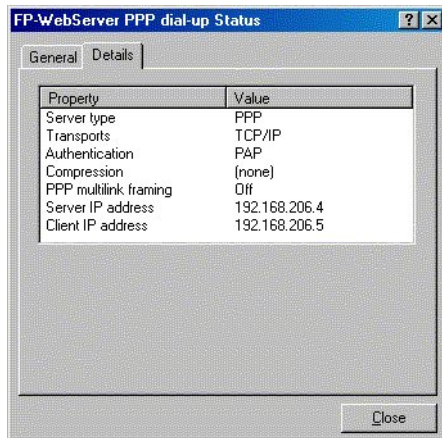
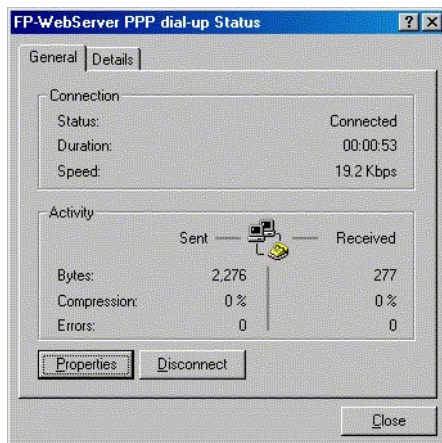

**NOTE**

If a Windows computer is set up to call up an Internet provider and to log on to the Internet via modem (as with private Internet access), you simply have to replace the telephone number of the Internet provider with that of the FP Web-Server (i.e. the modem connected to it).

### 9.1.3 Setup of the Modem Connected to the FP Web-Server for PPP-Communication

The modem has to be connected to the 9-pin RS232C port of the FP Web-Server.

The modem must be set up to support RTS/CTS flow control.

Using the FP Modem-EU for PPP communication is recommended. Its factory default setup can be used and it only needs to be connected via a 1:1 cable to the FP Web-Server.

RTS/CTS flow control needs to be enabled with AT&K3. To connect the modem to the FP Web-Server, refer to PPP-Server with modem (see page 163).

#### **Standard modem:**

Standard computer modems should be reset to the factory default state with the command AT&F&W. If there are connection problems, disabling the autoanswer mode with ATS0=0 or the Keybreak function with AT%K1 helps with some modems.

#### **GSM modem:**

- Be careful with the GSM antenna! Maintain distance to the other units (PLC, modem, FP Web-Server...), as it may cause interference by high level radio waves.
- Please reboot (power up) the FP Web-Server after changing cables and connectors. Especially after connecting a modem / GSM module to the FP Web-Server, it is necessary to restart the unit for modem initialization and recognition.

#### **Further information:**

ISDN Adapter (see page 136)

### **9.1.4 FP Web-Server PPP Gateway Functions**

---

The PPP-Server can be called up via modem by a PPP-Client, e.g. laptop with dial-up networking functions (see "Modem and Dial-up Networking Installation of a Windows Client" on page 111). As soon as the connection is established, you cannot only access the PLC and the FP Web-Server functions of the PPP-Server with this distant PPP-Client, but also contact all the other FP Web-Servers in the network via Ethernet!

The Ethernet (LAN) network and the dial-up networking connection have to be regarded as two separate networks, each with its own network address! For notes on IP addressing and distinguishing the network's and the unit's address, refer to IP and TCP/ IP (see page 166).

Within the LAN there is only one PPP-Server gateway allowed, i.e. if several FP Web-Servers are connected in a network via the Ethernet, only one of the FP Web-Servers in this network can assume the function of a PPP-Server.

When the IP configuration of the FP Web-Server is carried out, you can specify a default LAN gateway. As soon as a modem connection with the PPP-Server is established, this gateway address is replaced by the PPP configuration.



#### **◆ EXAMPLE**

---

#### **Configuration for an Initial Test:**

All FP Web-Servers in the Ethernet network need to have entered the gateway address of that FP Web-Server that implemented the PPP-Server access.

### Configuration example for the FP Web-Server that implemented the PPP-Server access:

The screenshot shows the 'Config' tab of the 'Configurator Project: Unit\_1\_Gateway'. The 'Ethernet IP Address' section has 'Get IP address from DHCP server' unchecked. The IP address is 172.148.180.1, Netmask is 255.255.255.0, and Gateway is 172.148.180.1. The 'PLC Interface' section shows Baud rate 19200, Data bits 8, Parity Odd, and PLC station address 1. The 'Domain Name Server' section has 'DNS enable' checked. The 'Password Protection' section has 'User name' as 'user' and 'Password' as '\*\*\*\*\*'. The 'Summary of enabled Functions' lists: \* Http server, \* MEWTOCOL port server, and \* Modem PPP-Server.

The following parameters need not to be changed and can also be used for your PPP gateway setup.

The screenshot shows the 'Dial-In' tab of the 'Configurator Project: Unit\_1\_Gateway'. The 'Enable PPP server' checkbox is checked. The IP address is 192.168.206.4, Netmask is 255.255.255.0, Gateway is 192.168.206.4, and Client address is 192.168.206.5. The 'Authentication' section has 'Mode' set to 'PAP' and 'Enable 2nd dial-in user' unchecked. The 'User name' is 'user' and 'Password' is '\*\*\*\*\*'. The 'Modem Settings' section has 'RS232C baud rate' set to 19200, 'Idle timeout in seconds' set to 360, 'Enable additional init. command' checked, and 'Modem ATcommand' set to 'AT&K3'. The 'Modem type' section has 'Analog modem, ISDN, GSM' selected.

### Configuration example of a second FP Web-Server in the LAN:

The screenshot shows the 'Config' tab of the 'Configurator Project: Unit\_2' window. The 'Ethemet IP Address' section has 'Get IP address from DHCP server' unchecked. The IP address is 172.148.180.2, Netmask is 255.255.255.0, and Gateway is 172.148.180.1. The 'PLC Interface' section shows Baud rate 19200, Data bits 8, Parity Odd, and PLC station address EE. The 'Summary of enabled Functions' lists 'Http server', 'MEWTOCOL port server', and 'Modem PPP-Server'. A 'Hilfe' button is at the bottom right.

### Configuration example of a third FP Web-Server in the LAN:

The screenshot shows the 'Config' tab of the 'Configurator Project: Unit\_3' window. The 'Ethemet IP Address' section has 'Get IP address from DHCP server' unchecked. The IP address is 172.148.180.3, Netmask is 255.255.255.0, and Gateway is 172.148.180.1. The 'PLC Interface' section shows Baud rate 19200, Data bits 8, Parity Odd, and PLC station address EE. The 'Summary of enabled Functions' lists 'Http server' and 'MEWTOCOL port server'. A 'Hilfe' button is at the bottom right.

With this configuration example, it was possible to test the IP\_forwarding successfully, i.e. a Windows computer that dialed up the FP Web-Server gateway was able to communicate with the other FP Web-Servers in the Ethernet LAN (were the Gateway-FP Web-Server is in). However, the [FIND] command of the Configurator (located on the remote Windows computer) could not find these FP Web-Servers because the IP broadcasts (using the [FIND] command of

the Configurator) may not be forwarded via a gateway. See the description of [FIND] and details at enter IP address manually how to configure these FP Web-Server via TCP communication.

### 9.1.5 FPWIN Pro Setup to Use the Remote Dialup Network

The standard function 'Remote Dialup Networking' of Windows is used for FPWIN Pro to communicate with an FP Web-Server via modem dialup. You can see how to set up Windows, FPWIN Pro and the FP Web-Servers in the following diagram:

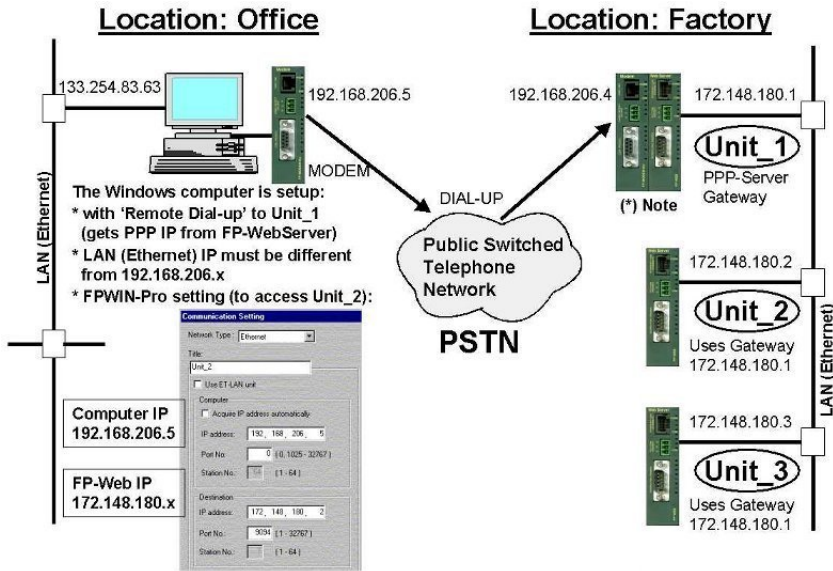

**NOTE**

See example setup in "Configuration for an Initial Test" of FP Web-Server PPP Gateway Functions (see page 119). The PPP server gateway Unit\_1 can also be set up to dial up the Internet to send an email.

**Comment:**

The Windows computer is set up as follows:

- with "Remote Dialup" to Unit\_1 (gets the PPP-IP from FP Web-Server)
- LAN (Ethernet) IP can be anything except for 192.168.206.xxx

- FPWIN Pro settings to access Unit\_2:

The screenshot shows the 'Communication Setting' dialog box. The 'Network Type' is set to 'Ethernet'. The 'Title' is 'Unit\_2'. Under the 'Computer' section, 'Use ET-LAN unit' is unchecked, 'Acquire IP address automatically' is unchecked, 'IP address' is '192, 168, 206, 5', 'Port No.' is '0', and 'Station No.' is '64'. Under the 'Destination' section, 'IP address' is '172, 148, 180, 2', 'Port No.' is '9094', and 'Station No.' is '1'. Callouts point to the 'Computer IP 192.168.206.5' and 'FP-Web IP 172.148.180.x'.

There are 3 IP sub-networks involved in this setup:

- 133.254.83.x: Computer Ethernet (any IP except 192.168.206.x or 172.148.180.x)
- 192.168.206.x: Computer + FP Web Modem (always use 192.168.206.x)
- 172.148.180.x: FP Web Ethernet (any IP except 192.168.206.x or 133.254.83.x)

#### Comments:

- Additionally (and in parallel) the FP Web-Server (Gateway Unit\_1) can be set up to use the modem for Internet dialup and email sending.
- For details on the PPP server settings of the FP Web-Server, refer to configuration example for the FP Web-Server that implemented the PPP-Server access (see page 119).

### 9.1.6 PPP Communication via Null Modem Cable

Some Windows versions allow a PPP connection to be established to the FP Web-Server via RS232C and null modem. Such an "RS232C - null modem cable" replaces both modems of the PPP connection, i.e. the computer's RS232C COM port is directly connected to the FP Web-Server's 9-pin port via a null modem cable.

**Windows 98 and Windows NT setup for IP communication via RS232C null modem cable:**



◆ PROCEDURE

Null modem driver installation:

1. **Locate the file "mdmcisc2.inf" on the setup-CD. Copy it to a temporary folder**
2. **Open the Control Panel of windows and double-click on the 'Modems' icon**
3. **If a modem is already installed click [Add]**
4. **Activate the checkbox "Don't detect my modem" and select [Next]**
5. **Click [Have Disk]**
6. **Select [Browse] and locate the temporary folder of "mdmcisc2.inf" and click [OK]**
7. **Select "Generic NULL Modem" and click [OK]**
8. **Select the COM port of the computer to be used (i.e. COM2) and select [OK]**
9. **Back on the main modems screen, select the new "Generic NULL Modem" and click 'Properties'**
10. **Set the maximum speed to the same value as specified in the FP Web-Server configuration (i.e. 38400)**
11. **Reboot the computer**

Remote Dialup Network Setup:

1. **Start → Programs → Accessories → Communications → Dialup Networking**
2. **Create a new connection (double-click on New icon)**
3. **Enter a name, e.g. "FP Web-Server null modem cable"**
4. **Select "Generic Null Modem" device**
5. **[Next]**
6. **Enter any number in the telephone number field. Click [Next] and [OK]**
7. **Back on the main 'Dial-up Networking': With the right mouse button click on new icon and select 'Properties'**
8. **Select 'Server' tab and select "PPP: Internet, Windows NT Server, Windows 98" from the pull-down menu**
9. **Under 'Advanced option', deactivate "enable software compression" and turn OFF "require encrypted password"**
10. **Under 'Protocol' select 'TCP/IP' only. Deselect 'NetBEUI' and 'IPX/SPX'**
11. **[OK]**

'Dial-up' and test the FP Web-Server:

1. **On the main 'Dial-up Networking' screen double-click on the new icon "FP Web-Server null modem cable"**
2. **Enter the name and password as defined in the FP Web-Server configuration (see above)**

The 'dial-up' process can take a few seconds. Upon a successful connection an icon is displayed in the system status bar.

To disconnect later, click on this icon and select 'Disconnect'.

3. **Use a standard Internet browser that is set up as described under Internet Browser to Test the FP Web-Server (see page 41)**
4. **In the location field the IP address of the PPP-Server can be entered, e.g. <http://192.168.206.4> (see FP Web-Server settings under PPP-Server (see page 109))**

The page "MAIN.HTM" as set up with the configurator should be displayed.

### **Windows 2000 and Windows XP setup for IP communication via RS232C null modem cable:**

Create a new "direct connection":

1. **Start → Settings → Network and Dial-up Connections → Make New Connection**
2. **Click [Next] and select "Connect directly to another computer". Click [Next].**
3. **Select "Guest" to define the PPP-Client. Click [Next].**
4. **At "Select a device:" locate the "Communication cable between two computers (COMx)". Click [Next].**

Comment:

COMx, i.e. the computer's RS232C COM port, should be used for the null modem cable. Perhaps the proper COM port number will not be found because it is already used by an installed modem driver. If necessary, remove the common modem driver (see "Control Panel / Telephone and Modem").

5. **Select "For all users". Click [Next].**
6. **Enter a name for this connection. For example "Null modem with COM1 and 19200bps to PPP-server". Click [Finish]**

The dial-up, connect screen is displayed.

'Dial-up' and test the FP Web-Server:

If the dial-up, connect screen is not displayed use: Start → Settings → Network and Dial-up Connections → "Null modem with COM1 and 19200bps to PPP-Server"

1. **Enter the name and password as defined in the FP Web-Server configuration. Click [Connect]**

The 'dial-up' process can take a few seconds. Upon a successful connection an icon is displayed in the system status bar.

To disconnect later, click on this icon and select 'Disconnect'.

2. **Use a standard Internet browser that is set up as described under Internet Browser to Test the FP Web-Server (see page 41)**
3. **In the location field the IP address of the PPP-server can be entered, e.g. <http://192.168.206.4> (see FP Web-Server settings under PPP-Server (see page 109))**



The page "MAIN.HTM" as setup with the configurator should be displayed.

### Pin assignment of the RS232C null modem cable

The computer's COM port is directly connected to the FP Web-Server's 9-pin port via a null modem cable.

Use a standard null modem adapter having 9-pin, female, RS232C connectors on both sides. The minimum wiring should be as follows: 2-3 ; 3-2 ; 5-5. (This is the minimum number of wires needed.) The minimum wiring connects the GND and the data lines only. A 25-pin connection should be as follows:

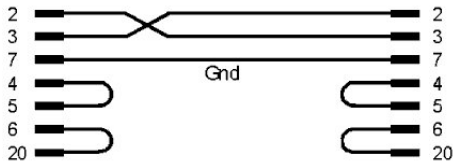

### Comment:

The bridges 4-5 and 6-20 on each side are not absolutely necessary. They are only essential for questions of compatibility.

## 9.2 Dial-In Inputs and Parameters for PPP-Server

In the following, the input fields of the "Dial-In" tab of the Configurator for the PPP-Server configuration are described.

The screenshot shows the 'Configurator Project: Example1' dialog box with the 'Dial-In' tab selected. The dialog is divided into several sections:

- Enable PPP server:** A checked checkbox.
- IP Address Fields:** Four input fields for IP address, Netmask, Gateway, and Client address, each with a label to its right.
- Authentication:** A dropdown menu set to 'PAP', a 'Mode' label, a checked checkbox for 'Enable 2nd dial-in user', and two input fields for 'User name' (containing 'user') and 'Password' (containing '\*\*\*\*\*').
- Modem Settings:** A section containing:
  - 'RS232C baud rate' dropdown set to '19200'.
  - 'Idle timeout in seconds' input field set to '360'.
  - 'Enable additional init. command' checkbox (unchecked).
  - 'Modem ATcommand' input field.
  - Four radio button options: 'Analog modem, ISDN, GSM' (selected), 'Null modem cable (standard)', 'Null modem Windows98, NT', and 'Null modem Windows2000, XP'.
- Help:** A button labeled 'Hilfe' at the bottom right.
- Footer:** A text box containing the instruction: 'For context-sensitive help, highlight button or entry field (using the TAB key) and press <F1>.'

For a detailed description of each field or button in the dialog, set the cursor into the field and press <F1> or highlight the button with <Tab> and press <F1>.

### Comments:

- The PPP-Client has to be set up in such a way that it accepts the remote IP address from the PPP-Server.
- The modem and the transparent TCP/ RS232C port cannot be used at the same time (except when a second FP Web-Server unit is used).
- The modem has to be connected to the 9-pin RS232C port of the FP Web-Server. The modem must be set up to support the RTS/CTS flow control.
- For a detailed description of the cables refer to PLC Connection, Cable Drawings, Modem (see page 162).



## **Chapter 10**

---

### **Dial-Out Setup for PPP-Client**

## 10.1 The Internet Dial-Out Function

### 10.1.1 Internet Email Settings

The following step-by-step procedure enables emails to be sent via Internet dialup:



#### ◆ PROCEDURE

1. Register an Internet email account with your email ISP if you do not have an Internet email account
2. Register an Internet dial-up account with your dial-up ISP if you do not have an Internet dialup account
3. In the Email section (see page 56), enter the email sender address of your account
4. In the Email section under [Email Server], define the email server settings including a POP3 login name and password

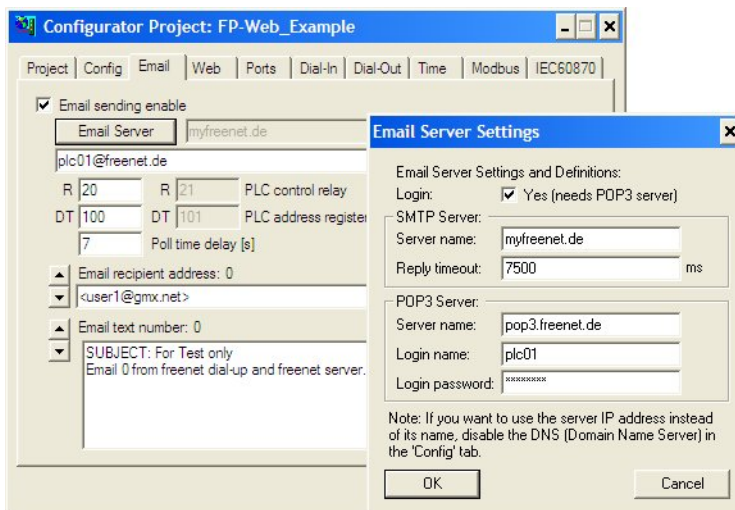

5. In the "Dial-Out (see page 138)" section, enable the check box "Dial-up Internet (modem at 9-pin connector)"

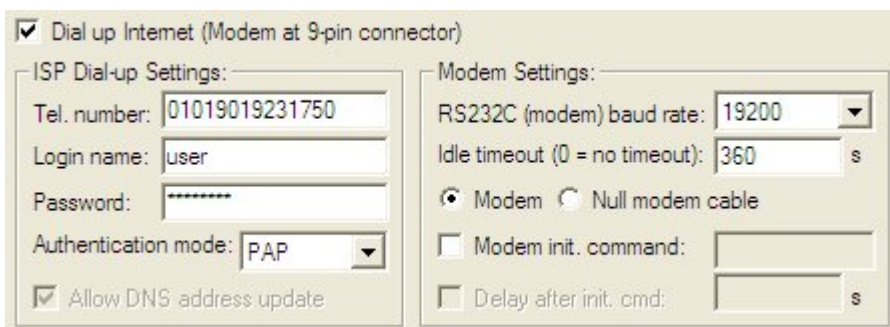

**6. Enter the telephone number for modem dial-up**

If you use a PBX, set the string "0" or "0w" (with delay after first zero) in front of the number.

**7. Enter the login name and password for the dial-up account**

The authentication method is normally set to "PAP".

**8. Set a baud rate that complies with the modem used**

The FP Web-Server always connects with the internal settings of 8 bits, none parity and 1 stop bit.

**9. Set the idle timeout**

The idle timeout can be lowered to approx. 2 minutes (120s). After this interval, if no data communication has occurred, the FP Web-Server disconnects from the dial-up ISP and hangs up the modem connection.



---

**◆ REFERENCE**

---

- For the settings on "Modem" or "Null modem cable", refer to the online help under modem or null modem cable selection
- For further settings, refer to the online help under the keywords "User modem init command" and "Delay after init command".



---

**◆ NOTES**

---

- For a "dial-out" connection, enable the PPP-Server function in the "Dial-In" section. This ensures that upon restart of the FP Web-Server, the modem is switched to offline (hang-up with +++ ATH). Moreover, the 'User modem init command' in the "Dial-In" section can be used for additional modem setup commands.
- For the FP Modem-EU Version 1.16, 19200bps are recommended (check the version with the command ATi3). In certain cases the function "automatic baud rate detection" does not work for all possible baud rates.  
Tip: Use a terminal and set the baud rate with the command AT\*W=xxxx to a fixed value, e.g. 19200. This disables automatic baud rate detection.
- If the modem connection from a remote client to the PPP server is established and an email is to be sent via Internet dialup by the FP Web-Server, the PPP server connection will be cancelled automatically so that it can call the ISP via modem. After the email is sent to the ISP, the PPP server is enabled again.
- For the user name and password, only ASCII characters are allowed. Do not use umlauts or Japanese characters.
- You can use either the Internet email server (check box is activated) or the transparent TCP/IP port because both need the RS232C port for data exchange.

**Comments:**

- It is possible to dial up one Internet Service Provider (Dial-up ISP) and use the email server(s) from a second ISP (email ISP). However, some ISPs will not allow this. Using one ISP for both dialup and email is recommended.
- In the Internet, email server(s) are normally addressed with a name rather than with its direct IP address. But for name resolution, the IP address of an Domain Name Server (DNS) is necessary. (FP Web-Server hardware version using BIOS v1.03 simplifies DNS usage).  
For easier configuration using the email server(s), direct IP addresses are recommended (...if they can be acquired and are not changed by the email ISP).
- An SMTP (Simple Mail Transfer Protocol) server is needed to send emails. An Internet SMTP server only allows registered users (registered email sender addresses) to send emails. Additionally some email ISPs protect their SMTP servers with a login procedure. For this a POP3 email server is used to check the user name and password before an email can be sent.  
Most of the time a POP3 login is used.
- You can also set up an FP Web-Server that is configured as a PPP-Server which can be dialed up by a distant FP Web-Server's PPP-Client (instead of an ISP). This FP Web-Server, i.e. the PPP-Server, works as a dialup gateway for a LAN where an email server can be used to send emails.
- For further details on special connections, please refer to the following:
  - "When Using a Cellular Phone (GSM) Modem (see page 135)"
  - "When Using GPRS Internet Connections (see page 136)"
  - "When Using ISDN Adapters (see page 136)"

**10.1.2 Notes for Advanced Users****Idle timeout**

If you use the FPWIN Pro library "M\_CE\_Lib" to send emails, you have to increase the idle timeout for Internet dialup operations. In the library delivered (see installation path "Programs / Panasonic MEW Control / FP-WEB2 / FPWIN-Pro\_Example") with FP-Web-Tool version 1.3 and later, the idle timeout is already set to 3 minutes.

Class	Identifier	Matsushita	IEC_Addre	Type	Initial	Au	Comment
0	VAR_GLOBAL	MAIL_PLC_CTR_srt	R20	%MXD.2.0	BOOL	FALSE	FP Web-Server start sending email
1	VAR_GLOBAL	MAIL_PLC_CTR_err	R21	%MXD.2.1	BOOL	FALSE	FP Web-Server error sending
2	VAR_GLOBAL	MAIL_PLC_POI_rec	DT100	%MW5.100	INT	0	FP Web-Server pointer to recipient address
3	VAR_GLOBAL	MAIL_PLC_POI_txt	DT101	%MW5.101	INT	0	FP Web-Server pointer to text string or file
4	VAR_GLOBAL	Server_Timeout			INT	1000	10.2s FP Web-Server timeout
5	VAR_GLOBAL	mail_add	DT200	%MW5.200	STRING[52]	<plc.web@>	Variable recipient address string
6	VAR_GLOBAL	mail_txt	DT300	%MW5.300	STRING[52]	'SUBJECT: > Email alert 1 Best regard	Variable email text string

**Gateways**

If your FP Web-Server is configured to use a gateway, i.e. if communication with the FP Web-Server is set up via a gateway, you need to take into account that the FP Web-Server does not use this gateway during an active dialup connection. This means that TCP port, FPWIN,

PCWAY or http communication through the gateway is temporarily interrupted while an Internet email is being sent.



**EXAMPLE**

- Before dial-up connection. The FP Web-Server can find all stations.

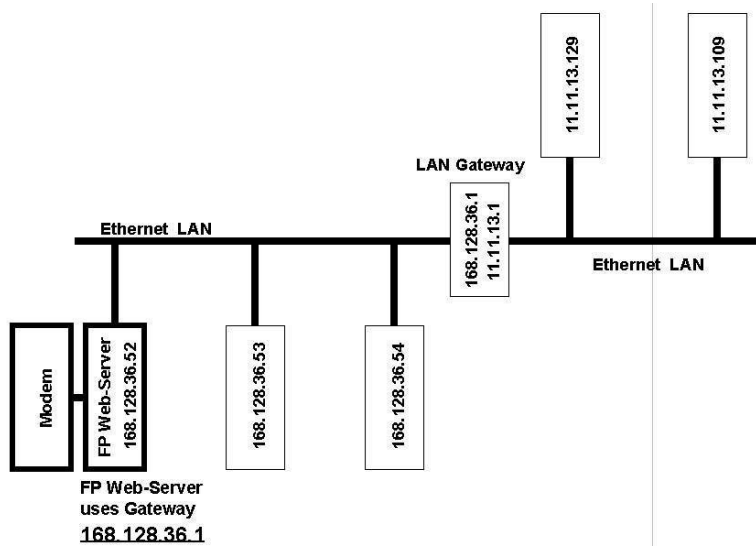



- **During dial-up connection. Both stations (e.g. 168.128.36.53 and 168.128.36.54 without using the gateway) can communicate with the FP Web-Server during the Internet dialup connection. The other stations (e.g. 11.11.13.129 and 11.11.13.109) that use the gateway may get communication errors while Internet dialup is active. This is valid for all connection modes of TCP communication, e.g. http, email, port communication and configuration (Telnet, FTP).**

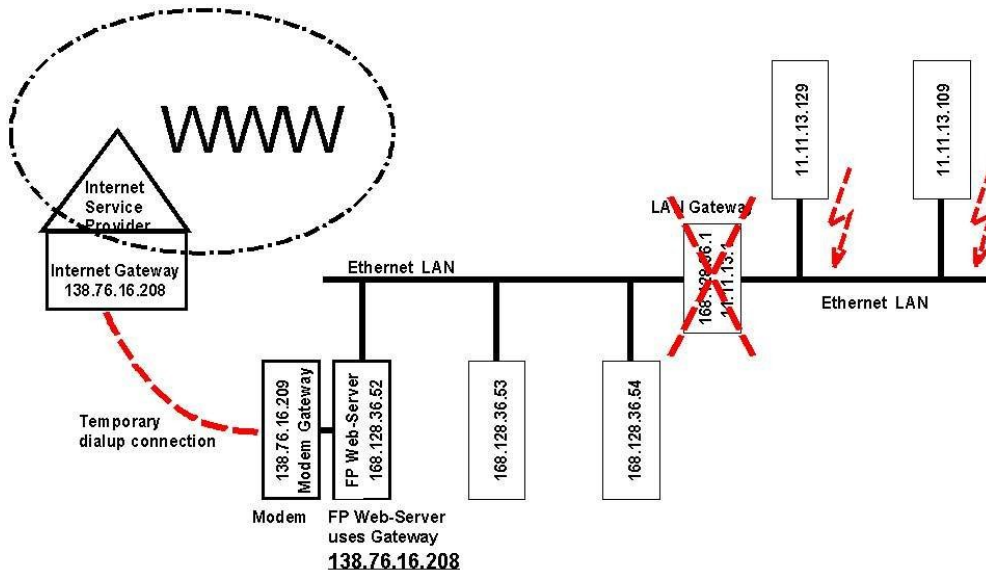

### Blocked emails

Some email ISPs, e.g. GMX, may block sending emails if the PLC sends too many emails or emails are sent in quick succession. No official documentation or explanation could be found at GMX. It can be assumed that GMX blocks sending 'swamp mail'.

### Modem connection and setup

The FP Web-Server's dial-out (PPP-Client) function is set up for RTS/CTS handshake (pin 7 and 8 of the 9-pin connector). The following two paragraphs describe how to setup the modem to also support RTS/CTS handshake. Only if the connected modem cannot support RTS/CTS handshake should pin 7 be bridged to pin 8. However, this is not recommended and should only be used with a slow modem baud rate (max. 9600 or 19200 bps).

- The FP Web-Server firmware is designed for a FP Modem-EU connected to its 9-pin port for Internet dialup. For this a 1:1 9-pin RS232C cable (standard computer to modem cable) can be used to connect the FP Modem-EU to the 9-pin connector of the FP Web-Server.  
The FP Web-Server assumes the FP Modem-EU factory default settings. To make sure that the FP Modem-EU has factory settings, please use a terminal program on your computer and enter the command AT&F&W. Please also make sure that all DIP switches of the FP Modem-EU are set to the **OFF** position!
- If a standard computer modem is to be used it can also be connected by a 1:1 9-pin RS232C cable (standard computer to modem cable) to the 9-pin connector of the FP Web-Server. Before the modem is connected to the FP Web-Server, please use a

terminal program to enter the appropriate AT commands (see modem manual):

- Ignore DTR changes (AT&D0)
- RTS/CTS hardware handshake (AT&K0&R0)
- No wait on dial tones (ATX3)

This setting is saved with the command AT&W for the next power-up or ATZ command. If the modem is connected via a PBX to the PSTN, a "0w" or "0" can be put in front of the Dialup ISP telephone number.

### Dialup and email tests

The enhanced email functions like POP3 login and name resolution via DNS can also be tested in a LAN, i.e. also in the local Ethernet a POP3 login and DNS access can be tested. The network administrator can provide the parameters and addresses.

To test the Internet dialup and the Dialup ISP parameters, a Windows computer with 'remote dialup networking' can be used. This setup plus an email client like "Eudora" or "Outlook" can be used to test the email servers and the Email ISP parameters.

For tests in Germany, we included "Example7".

Later versions will implement an extended status display.

### FP Web-Server configured as a PPP-Server

You can also configure a second FP Web-Server as a PPP-Server which can then be dialed up instead of an ISP. This remote FP Web-Server, i.e. the PPP-Server, works as a dialup gateway for a LAN where an email server can be used to send emails.

---

## 10.1.3 When Using a Cellular Phone (GSM) Modem

---

Please note the following when a cellular phone (GSM) module is used by the FP Web-Server to call an ISP before sending an email:

1. At the dialog "Email Server Settings" enter a high value (17000ms or more) for the timeout of the DNS and Email Server.
2. At the dialog "Internet Dialup Settings" only the baud rate can be set. The FP Web-Server always uses 8 data bits, no parity and 1 stop bit.
3. Be careful with the GSM antenna! Maintain distance to other units (PLC, modem, FP Web-Server...), which may cause interference by high level radio waves.
4. Set the GSM module to the factory settings (default settings) before connecting to the FP Web-Server.
5. Please reboot (power up) the FP Web-Server after changing cables and connectors. Especially after connecting a modem / GSM module to the FP Web-Server, it is necessary to restart the unit for modem initialization and recognition.
6. Most of the GSM providers also offer Internet services. In this case these providers will not allow you to dial up other Internet Service Providers via GSM! I.e. if you have a GSM contract with company **XYZ** and this company also offers Internet dial-up services, you cannot use your GSM module to dial up Internet services from the other company, e.g. **ABC**.
7. The PIN code entry command AT+CPIN=xxxx can be entered in the text field

"Additional User Modem init. command" in the tab "Dial-In (see page 127)" or/and "Dial-Out (see page 138)".

### 10.1.4 GPRS Internet Connections

---

In general a GPRS connection is set up in the same way as a regular PPP dial-up (see page 138) connection. The exceptions are:

- The telephone number of the Internet dial-up provider is replaced by \*99\*\*\*1#
- Only a connection to the Internet is possible
- The data amount transferred is billed (not the online time as with GSM)
- A special +CGDCONT parameter (provider-dependent) is needed to set up the module

We have tested the Siemens MC35 and the Wavecom Fastrack GPRS units. Both are to be set up in a similar way. For the Siemens MC35 the two parameters +CGDCONT and +CGQREQ are automatically set up with the SIM card. For the Wavecom Fastrack you have to initialize it once manually. Use a terminal with 9600 8n1 and enter AT+CPIN=xxxx to log onto the network. Then enter:

1. AT+CGQREQ=1,3,4,3,0,0 (Provider-dependent)
2. AT+CGDCONT=1,"IP","Internet.t-d1.de" (Provider-dependent)
3. AT+IPR=0 (Automatic baud rate detection)
4. AT+IFC=2,2 (RTS/CTS handshake)
5. AT&W

In this example the parameters for the German GPRS provider "T-Mobile" were used. Please ask your GPRS provider for the correct parameters.

The 'Modem init command' in the "Dial-Out" section can also be used for additional modem setup commands such as AT+CGDCONT=. Or it can be used for the PIN code entry. The AT commands listed here are transferred to the modem shortly before the dial-up command for the Internet.

For GPRS "dial-out" connection, enable the PPP-Server function (see page 127) in the "Dial-In" section. The 'Modem init command' in the "Dial-In" section can be used for additional modem setup commands. Maybe the AT+CGDCONT command can be entered here.

For continuous Internet connections via GPRS, enable "periodic communication test function".

For GPRS connection, hardware version 1.0 should not be used.

For details, refer to the online help under 'Example12', which demonstrates how to set up and test continuous GPRS Internet connection. .

### 10.1.5 When Using ISDN Adapters

---

The PPP-Server (dial-in) and PPP-Client (dial-out) of the FP Web-Server can also handle ISDN modem adapters for remote connections. Following are some hints to use the FP ISDN 64k adapter from PEW Germany:

- Enable the PPP-Server (dial-in) also for dial-out connections
- Reset the FP ISDN 64k with AT&F3 (see dial-in user init. command)
- Possible modem baud rate up to 57600 bps
- RS232C cable from the FP ISDN 64k to the 9-pin Sub-D of FP Web-Server:

<b>FP ISDN 64k</b>	<b>FP Web-Server</b>
FG -----	2 ( yellow)
+ -----	3 (green)
- -----	5 (brown)
	7 --- 8 bridge in d-sub
	4 --- 1 --- 6 bridge

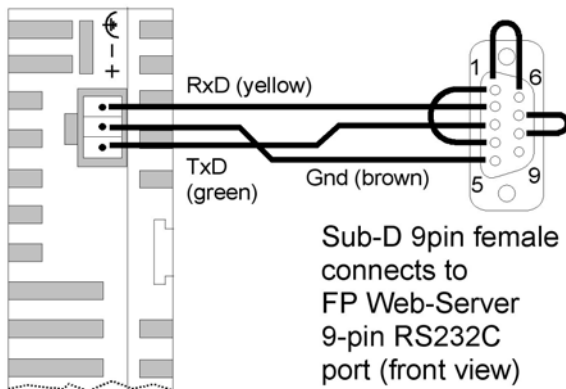

## 10.2 Internet Dial-Out Settings

Open the "Dial-Out" Tab in the Configurator and enable the check box "Dial-up Internet Service Provider (ISP) for email..." to configure the settings for:

- ISP Dial-up
- Modem
- Continuous Internet connection

Configurator Project: Example10

Project | Config | Email | Web | Ports | Dial-In | Dial-Out | Time | Modbus | IEC60870

Dial-up Internet Service Provider (ISP) for email ... :

Dial up Internet (Modem at 9-pin connector)

ISP Dial-up Settings:

Tel. number: 01019019231750

Login name: user

Password: \*\*\*\*\*

Authentication mode: PAP

Allow DNS address update

Modem Settings:

RS232C (modem) baud rate: 19200

Idle timeout (0 = no timeout): 360 s

Modem  Null modem cable

Modem init. command: AT

Delay after init. cmd: s

Continuous Internet Connection (GPRS):

Stay online after dial-up and sending email

Communication test every 12 min

R 22 PLC control relay

DDT 102 PLC info IP register

Central Internet Server Logon

Address setup under 'Email Settings'

For context-sensitive help, highlight button or entry field (using the TAB key) and press <F1>.

Hilfe



### ◆ NOTE

**The modem must be set up to support the RTS/CTS flow control. Together with the PPP-Client, we recommend enabling the PPP-Server (see page 127). It also allows you to enter an optional, additional, user-defined modem initialization command.**

For a detailed description of each field or button in the dialog, set the cursor into the field and press <F1> or highlight the button with <Tab> and press <F1>.

## **Chapter 11**

---

# **NTP Server for PLC Clock Synchronization**

## 11.1 (S)NTP Servers

This function is used to synchronized the PLC clock with a network time server.

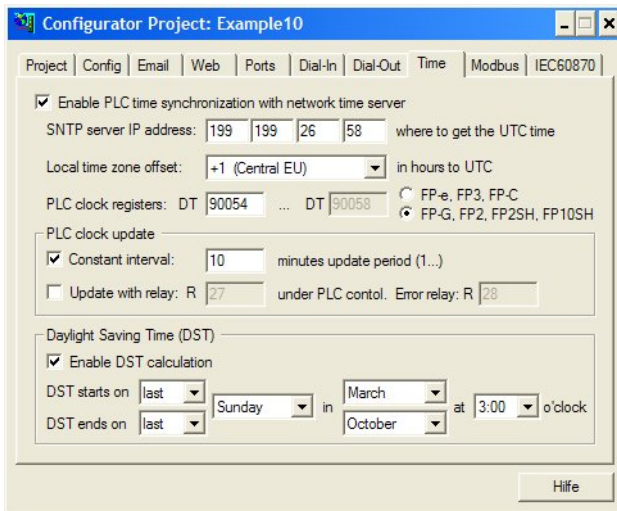

For a detailed description of each field or button in the dialog, set the cursor into the field and press <F1> or highlight the button with <Tab> and press <F1>.

In most LANs a Network Time Server (NTP or SNTP) is available to synchronize the real-time clock (RTC) and calendar date of the network units (computers). Such NTP servers provide accurate world date/time information in UTC format (Universal Time Coordinate).

The FP Web-Server can request the current UTC time from the NTP server. Optionally the FP Web-Server can calculate the local time with a daylight saving time (DST) offset. And then the FP Web-Server can update the date/time RTC registers within the PLC. The update of the PLC clock can be done independently of the PLC program in constant time intervals.

Additionally the FP Web-Server can be set up in this way so that a PLC-controlled internal relay can trigger a PLC clock update.

The FP Web-Server can also save clock information in a user-definable DT register address. This is especially useful for PLCs having no integrated RTC.



### ◆ NOTE

**The separate battery must be installed to use the RTC functions of the FP-Sigma.**

The time function is mainly designed to request the current time from an NTP server located in the LAN to update the PLC clock. "Example15" also shows how to dial up the Internet to request the time from an Internet NTP server to update the PLC clock.

For more information on world time and DST see:

- <http://www.worldtimezone.com/>
- <http://www.twinsun.com/tz/tz-link.htm>

- <http://www.weltzeituhr.com/>

**NOTES**

---

- **Please be aware that an enabled NTP module takes up about 11kB of the FP Web-Server's FLASH memory.**
- **The server timeout is 2 minutes, i.e. the NTP server must respond to the time request of the FP Web-Server within 2 minutes.**





# Chapter 12

---

## Modbus Functions

## 12.1 Overview on Modbus-TCP Functions of the FP Web-Server

### General Information on Modbus-TCP

The Modbus-TCP is a standard global communication protocol (IAONA, Modbus-IDA) and is used to connect the PLC to third-party PLC equipment, SCADA systems, OPC servers, and Modbus-RTU gateways.

A Modbus-TCP server waits for an incoming connect from a Modbus-TCP client. Hence:

- A Modbus-TCP server (Ethernet) is comparable to a Modbus-RTU slave (serial).
- A Modbus-TCP client (Ethernet) is comparable to a Modbus-RTU master (serial).

A Modbus-TCP server is addressed with a unique IP address and a port number (default 502). Using a unit ID address in the Modbus-TCP data packet, various interfaces of the Modbus-TCP server can be addressed. The unit ID is comparable to the slave address in Modbus-RTU communication.

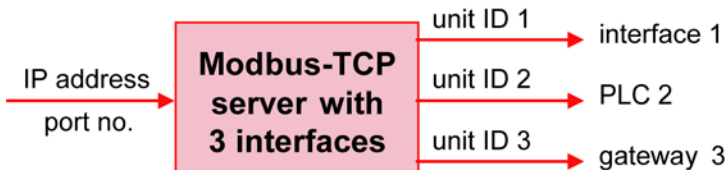

Modbus communication is based on a number of specified function codes which can address different data types. Which function codes and data types are supported depends on the unit implementation.

### FP Web-Server Specific Implementation

The FP WEB Configurator Tool Version 2.1 allows you to configure the FP Web-Server (as an interface to the PLC) with the following Modbus-TCP server and client functions.

Function		Comment
<b>A</b> <b>Modbus-TCP Server</b> (see page 146)	A1 Modbus-TCP Server	Modbus-TCP Client → FP Web-Server → PLC (see note 2)
	A2 Modbus-TCP Server	Modbus-TCP Client → FP Web-Server → multiple PLCs (see note 1 and note 2)
	A3 Modbus-TCP Server Gateway	Modbus-TCP Client → FP Web-Server → Modbus-RTU Slave (see note 1)
<b>B</b> <b>Modbus-TCP Client</b> (see page 148)	B1 Modbus-TCP Client	PLC → FP Web-Server → Modbus-TCP Server
	B3 Modbus-TCP Client Gateway	Modbus-RTU Master (see note 1) → FP Web-Server → Modbus-TCP Server
In addition: Modbus-RTU functions (for PLCs that do not support Modbus-RTU protocol)	B2 Modbus-RTU Master	PLC → FP Web-Server → Modbus-RTU Slave (see note 1)
	B4 Modbus-RTU Slave	Modbus-RTU Master (see note 1) → FP Web-Server → PLC

For an overview on all functions, please refer to the block diagram (see page 10).



## ◆ NOTES

---

1. **This function uses the 2nd RS232C (9-pin Sub-D connector).**
2. **Since Modbus protocol, in contrast to the PLC, only recognizes 4 different memory areas, a configurable Address-Translation-Table was implemented. This allows you to configure offsets so that Modbus "coils" and "registers" correspond to the PLC's memory areas: X, Y, R, DT, FL, WR, etc.**
3. **Various functions can be combined and used simultaneously.**
4. **Most functions support the same list of Modbus function codes.**
5. **You can configure all these functions manually or with the help of the wizard.**

## 12.2 Modbus-TCP Server of the FP Web-Server in General

The FP Web-Server can be accessed by a Modbus-TCP client (SCADA) via Ethernet for PLC data communication. To do so, the FP Web-Server requests PLC data (MEWTOCOL protocol) via the 3-pin or/and 9-pin RS232C port. The 9-pin RS232C can alternatively communicate via Modbus-RTU protocol with a Modbus-RTU slave unit.

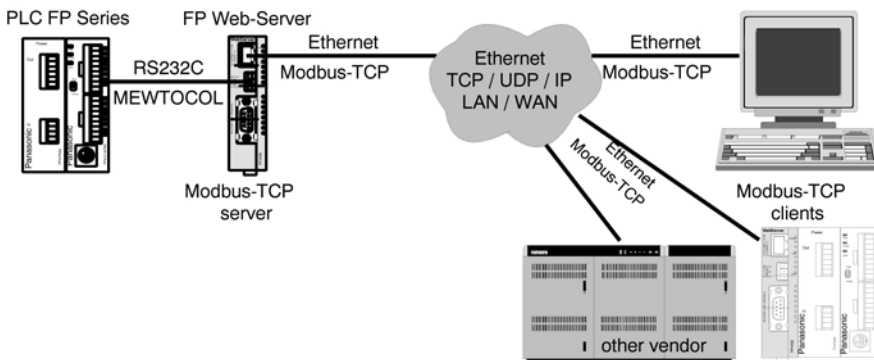

Modbus-TCP communication can also occur via modem. To do so, the client must first dial up the FP Web-Server's PPP-Server to establish a modem connection.

The Modbus-TCP server can handle up to 6 client connections simultaneously. If there are already 6 connections and another client wishes to establish a connection, the oldest connection can be ended automatically.

Up to 3 different port numbers are possible. Alternatively, these ports can be switched to UDP communication where each UDP port is assigned one task. Both of the FP Web-Server's RS232C ports can be addressed.

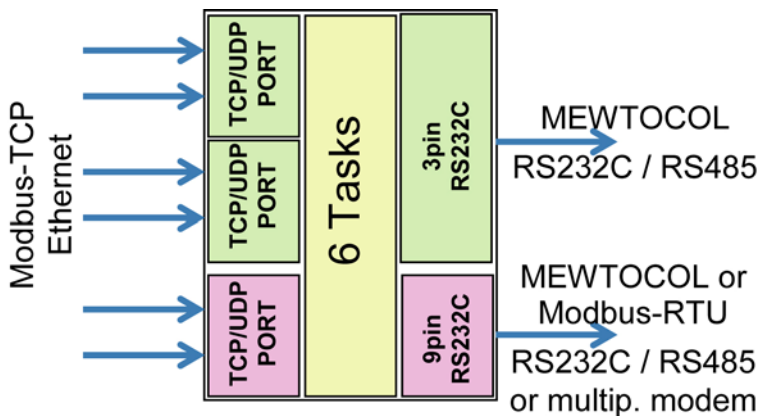

**Features:**

- The Modbus-TCP client can address the FP Web-Server's two RS232C ports (MEWTOCOL or Modbus-RTU) by using a port number or unit ID.

Detailed information:

For more information on Modbus-TCP server settings and the respective server functions, please refer to the online help under the keyword "Modbus-TCP Server Settings".

- This function uses the configurable Modbus to PLC address translation table.
- The gateway function routes all Modbus function requests.
- The Modbus-TCP server can handle UDP broadcast messages (FP-WEB2 does not generate a response message).
- An integrated setup wizard helps you configure the Modbus-TCP server.
- NumberMaxOfServerTransactions = 6
- SO-RCVBUF, SO-SNDBUF = 4kB with TCP and 2kB with UDP (other IP stack parameters can be defined)

## 12.3 Modbus-TCP Client of the FP Web-Servers in General

Either the PLC or a Modbus-RTU master unit can control the Modbus-TCP client functions of the FP Web-Server.

- For PLC control a shared buffer in the PLC's memory is used. The PLC program places the server IP address and Modbus commands in this buffer. The FP Web-Server reads the buffer and executes the commands. Additionally, the PLC can also access a Modbus-RTU slave unit via the 9-pin RS232C interface.
- Any Modbus-RTU master connected to the 9-pin RS232C of the FP Web-Server can access a remote Modbus-TCP server. This gateway routes all Modbus-RTU function requests to the Modbus-TCP server. Optionally the Modbus-RTU master can address different Modbus-TCP servers (IP address and/or unit ID is calculated by the accessed RTU slave address) or the local PLC directly.

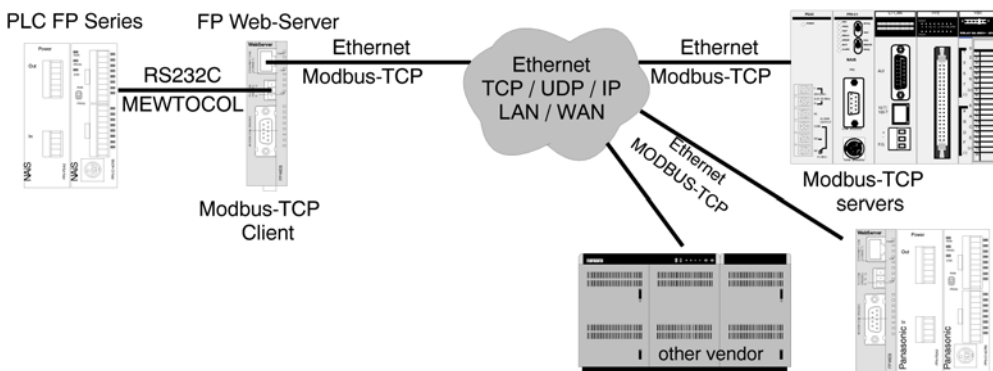

The Modbus-TCP communication can also be done via modem. For this the client (FP Web-Server controlled by the PLC, see PLC sample program "Dialup-StayOnline.asc") has to dial up the Modbus-TCP server to establish a modem connection before Modbus-TCP communication can take place.

The PLC can also control continuous, automatic data exchange via Modbus protocol. See PLC sample program "Modbus-TCP-Client.asc", which is installed along with the FP Web-Configurator.

### Features:

- This function uses the configurable Modbus-to-PLC address translation table.
- The gateway routes all Modbus function requests.
- The Modbus-TCP client can also handle UDP broadcast messages (all responses from the servers are ignored).
- An integrated setup wizard helps you to configure the Modbus-TCP client.
- NumberMaxOfClientTransactions = 6 (if all are busy, then the oldest is disconnected).
- SO-RCVBUF, SO-SNDBUF = 4kB with TCP and 2kB with UDP (other IP Stack parameters can be defined).

**Further information:**

For more information on Modbus-TCP client settings and the respective client functions, please refer to the online help under the keyword "Modbus-TCP Client Settings".



## 12.4 Appendix for Modbus Functions

---

The following sections are described here:

- Combining multiple Modbus Functions
- Address Translation Table
- Supported Modbus Functions
- Modbus-TCP Server Performance
- PLC Buffer Definition for the Modbus-TCP Client
- Sample PLC Programs to Control the Modbus-TCP Client Functions

For more information, please refer to the online help under the keyword "Appendix for Modbus Functions".

## **Chapter 13**

---

# **IEC 60870 Functions of the FP Web-Server**

## 13.1 IEC 60870 General Functions

---

The following connections to the FP Web-Server are possible:

1. The PLC is connected to the FP Web-Server via a 3-pin RS232C up to 115200 bps (see PLC connection to the FP Web-Server (see page 162)).
2. IEC 60870-5-101 Unbalanced Communication (9-pin RS232C of the FP Web-Server unit)
  - directly via RS232C to the central station
  - Multipoint via C-Net (RS485) adapter (AFP8536) up to 19200 bps
  - Multipoint via FP Modem-EU (V.23 via twisted pair cable) with 1200 bps
  - PSTN modem dialup connection (extension specified by OHP). This connection receives calls from and/or dials out to the central station. Analog modem, ISDN adapter or GSM module can be used.
3. IEC 60870-5-104 communication (via RJ45 Ethernet connector of the FP Web-Server unit)
  - via Ethernet
  - TCP/IP communication also possible via PPP-Server and dialup modem connections

### Comment:

If an IEC 60870-5-104 Ethernet connection is established from the central station to the FP Web-Server, an IEC 60870-5-101 connection via RS232C is impossible. As soon as there is no Ethernet connection, the IEC 60870-5-101 connection can be established via RS232C again.



### ◆ NOTES

---

- Using IEC 60870 communication the PLC needs to execute special IEC 60870 function blocks. These PLC function blocks are delivered as an FPWIN Pro library together with the FP WEB Configurator Tool. The IEC 60870 FPWIN Pro library, accompanying examples and interoperability documentation can be installed from the FP WEB Configurator Tool CD-ROM. For details refer to the Library's online help (see page 156).
- If the IEC 60870 functions are to be used (checkbox "Enable IEC60870" is active), disable standard FP Web-Server's functions like http, email, PPP server or port function (see page 104). If these standard functions are enabled at the same time as the IEC 60870 protocol, the reaction time and performance of the FP Web functions may slow down.
- If the 9-pin RS232C port is set up for IEC60870-5-101 communication, MEWTOCOL communication can take place. The IEC60870 polling from the central station must be stopped before MEWTOCOL communication can be used. MEWTOCOL commands are sent directly to the PLC. This version only allows short (standard) MEWTOCOL commands.

Perform the following steps to disable extended MEWTOCOL commands for FPWIN Pro:



## PROCEDURE

1. Locate file "NAiS\_MewPLC.DAT" under C:\Program Files\NAiS MEWNET
2. Open "NAiS\_MewPLC.DAT" with a text editor, e.g. Notepad
3. Find the section for your PLC, e.g. [FPSIGMA] or [FP2]
4. Set the parameter EXTCMD=0 to zero
5. Save changed file "NAiS\_MewPLC.DAT"
6. Restart FPWIN Pro

### 13.1.1 Details of the IEC 60870 Configuration: Modem and Multipoint Settings

#### 1.) Multipoint with FP Modem-EU

- line parameter: half duplex 1200 bps (independent from the RS232C baud rate)
  - communication via V.23 mode 2 norm via twisted pair cables
  - terminator: see manual of FP Modem-EU
- modem setup: initialization with PC and terminal program
  - set all DIP switches of the modem to OFF and connect to the PC
  - set the terminal to 1200 bps, 8 data byte, parity ODD and 1 stop bit (see note 1)
  - Use the terminal to reset the modem to AT&F&W
  - store the settings of RC232 format (see note 1)
  - AT\*W=1200,8,O,1
  - set modem DIP switch 2 to ON
- connect the modem to RTI (RTU) via the standard modem cable 1:1
- RS232C signal (PC mode): DCD shows status line, i.e. line is busy
- RTS initializes sending: CTS after RTS means OK to send
- Settings for **RTI** (Lian98 from Ver 1.0.1.2 onwards):
  - baud rate, data byte, parity, stop bits set to same values as the modem (\* Note)
  - timeout 280ms minimum
  - modem: half duplex
  - transmission: unbalanced
- Settings of **RTU** (IEC Communicator):
  - baud rate, data byte, parity, stop bits set to same values as the modem (\* Note)
  - handshake: RTS/CTS

- mode: Multipoint-party line



## ◆ NOTES

1. Parity Even and a baud rate other than 1200bps are only available from FP Modem-EU firmware version 1.23 onwards (use ATi3 to display the version).
2. The same baud rate is recommended for the use of RTI and RTU.
3. The FP Modem-EU multipoint communication is compatible with standard industrial multipoint units.

## 2.) Multipoint with C-Net adapter

- line parameter: half duplex RS485
  - baud rate: format as RS232C (up to 19200 bps)
  - terminator: see manual of the adapter used
- C-Net adapter: AFP8536 is tested only
  - no handshake is used
- RS232C cable from AFP8536 to RTI / RTU:
  - AFP8536: 9-pin RS232C female
  - RTI/RTU: 9-pin male IBM PC standard

AFP8536	PC
pin 2 ---- pin 2	
pin 3 ---- pin 3	
pin 7 ---- pin 5	
bridge: pin 4 -- pin 5	bridge: pin 7 -- pin 8
bridge: pin 8 -- pin 9	bridge: pin 4 -- pin 6
- Settings for **RTI** (Lian98 from Ver 1.0.1.2 onwards):
  - baud rate 19200bps
  - data byte, parity, stop bits set to same values as RTU
  - timeout 200ms minimum
  - modem: full duplex
  - transmission: unbalanced
- settings for **RTU** (IEC Communicator):
  - baud rate 1200bps
  - data byte, parity, stop bits set to same values as RTI
  - handshake: NONE
  - mode: RS232C

## 13.2 Parameters for IEC 60870

Open the "IEC 60870" Tab in the Configurator for the following settings:

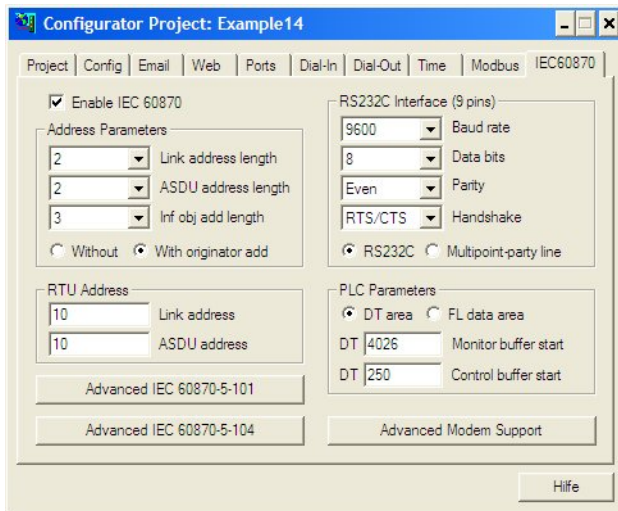

For a detailed description of each field or button in the dialog, set the cursor into the field and press <F1> or highlight the button with <Tab> and press <F1>.

### 13.3 IEC 60870 Library for Control FPWIN Pro

---

To use the IEC 60870 functionality of the FP Web-Server, a library for Control FPWIN Pro is delivered with your Installation CD. For details refer to the online help of the Library. Click [Start] -> Programs -> Panasonic MEW Control -> M\_IEC60870\_LIB.chm to open the online help for the FPWIN Pro Library.

Please find the library "M\_IEC60870\_LIB.sul" for FPWIN Pro with the respective examples and the description of the interoperability that came on your Installation CD. Only both, the setup of the library **and** the setup of the Configurator enable IEC 60870 functionality, whether the Configurator or the Library is installed first.

## **Chapter 14**

---

### **Java Applet Library "MEW.JAR"**



## 14.1 Introduction to FP Web-Server and the Java Applet "MEW.JAR"

---

### Enhance your HTML Pages with Java Applet Windows:

The Java Applet technology can be used for complex, high-speed, dynamic PLC data visualization in Internet Browser windows. Java applets can help to improve your HTML pages. You only need standard software, the MEW.JAR Java Applet Library and minimal HTML design knowledge.

### General:

Java Applets are user application programs written in the programming language Java. These programs are stored together with the HTML files in the Http-Server section on the FP Web-Server unit. The Java Applet file has the file extension .JAR (Java Archive). An Internet browser and a special tag within your HTML page are needed to download the .JAR to the computer. The Java Applet program is then started by the Internet browser and runs on the computer in a secure area ('Sandbox'). Each Java Applet has its own window which can be freely resized and positioned within your HTML page. Parameters within the HTML page can be used to configure the Java Applet functions.



### Java Applets Compared to HTML and Java Script:

Normally web pages are designed by using HTML and Java Script (DHTML) code, which allow only very limited dynamic features to be implemented. Moreover, DHTML is not very fast and is not compatible with the various Internet browsers. The programming language Java, which is used to design Java Applets, is a powerful, future-oriented tool for programming huge applications. Java code can run on various computer systems, e.g. Linux and Solaris. Java code runs in a separate, secure area and hence cannot compromise the computer.

### The Java Runtime System:

Java program code cannot be executed directly by the computer's CPU (Windows, Linux, Solaris...). Java code is a kind of intermediate or meta code and needs a special software to be interpreted and executed. The required Java interpreter software from the company SUN is called 'Java 2 Runtime Environment', or in short 'JRE'.



### ◆ REFERENCE

---

For more information on the Java Applet Library, please refer to the online help under the keyword "Java Applet Library" or to the pdf file "JavaAppletLibrary.pdf" on your installation CD-ROM in the sub-folder "JavaApplets".

# Chapter 15

---

## Additional Information

## 15.1 Contents of the CD and Auxiliary Programs

You will find the following folders on the CD:

Folder	Subfolder	Comment
FP-Web-Configurator		Configurator Setup including examples for http and FPWIN Pro
FP-Web Documents		Different documentation, Manuals
FP-IEC60870 Library		Setup of FPWIN Pro IEC 60870 library, examples and documentation of inoperability
JavaApplets		Documentation on the Java Applet Library
	JavaAppletLibrary	Setup of the Java Applet Library including examples and additional tools
	JavaRuntime	Setup of the Java runtime system for Windows (SUN)
Other Tools	AcrobatReader	Enables displaying pdf files
	COM_IP	RS232C to Ethernet Redirector
	Flash_Plugin	Required to display Flash graphics in the HTML help
	HtmlHelp Workshop	Necessary tools when the display of the HTML help fails
	RS232C_TCP Redirector	Redirector using two COM Ports
	PPP-Cable	PPP Connection via Null Modem Cable plus driver for the FP Modem-EU (now supports all versions of Windows NT)
	TCP_Server_Client	Visual Basic and C++ examples for programming a TCP server or client application for windows.



### ◆ NOTE

**Please pay attention to possible license regulations!**

## 15.2 Description of the HTML Examples

---

The following examples supplied with the installation of the FP Web-Server configurator show in a simple way the HTML functions of the FP Web-Server and may be used as source material for advanced projects. All examples for editing can be found in the installation directory of the FP Web-Server under "Program Files/ Panasonic MEW Control/ Configurator/ FP-WEB2/ Example..".



---

### ◆ REFERENCE

---

For a detailed description of each example, please refer to the online help under the keyword "Example" and the respective number of the example.

## 15.3 PLC Connection, Cable Drawings, Modem



### ◆ NOTE

Please also see the installation sheet "FPWEB\_Server\_Leaflet" supplied with your FP Web-Server for important notes, cables and installation.

To connect and wire to an Ethernet, please refer to "Setup of an Individual Ethernet LAN (see page 168)".

### 15.3.1 PLC Connection

Cables for the FP Web-Server:

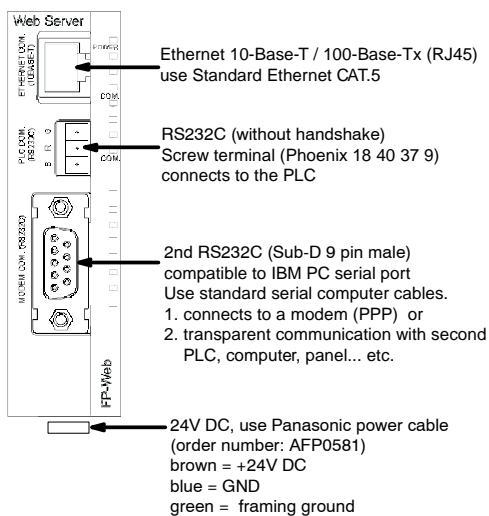

**Note: The green wire MUST be connected to FG!**

### 15.3.2 Cable Drawings and Modem

The possible cables for connecting the FP Web-Server to a Panasonic PLC:

**Tool port FP-X/e/0/Σ M/2/2SH using cable AIGT8192**

FP Web-Server Screw Terminal 3-pin	PLC Tool Port Sub-D male 5-pin	Description
G _____	1 (brown)	G (GND) = System ground
R _____	2 (red, white)	R (RXD) = Receive data
S _____	3 (orange, green)	S (TXD) = Transmit data

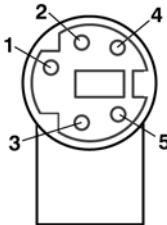

**COM port FP1/M/2/2SH/10SH, SDU FP2/3 using cable AIP81842**

FP Web-Server Screw Terminal 3-pin	PLC COM. Port Sub-D male 9-pin	Description
G _____	7 (brown)	G (GND) = System ground
R _____	2 (red, white)	R (RXD) = Receive data
S _____	3 (orange, green)	S (TXD) = Transmit data
	4	
	5	

**COM port FP-e/FP0**

FP Web-Server Screw Terminal 3-pin	PLC COM. Port Screw Terminal	Description
G _____	SG/G	SG/S (GND) = System ground
R _____	SD/S	RD/R (RXD) = Receive data
S _____	RD/R	SD/S (TXD) = Transmit data

**COM1, 2, 4 modules FP-X/FPΣ**

FP Web-Server Screw Terminal 3-pin	PLC COM1/4 Screw Terminal	PLC COM2 Screw Terminal	Description
G _____	SG _____	SG	G/SG (GND) = System ground
R _____	SD _____	S1	R/RD/R1 (RXD) = Receive data
S _____	RD _____	R1	S/SD/S1 (TXD) = Transmit data
	RS } CS }		only COM1

G (GND) = System Ground

R (RxD) = Receive Data

S (TxD) = Transmit Data

The 3-pin screw terminal is from Phoenix: Phoenix product: MC1,5/3-ST-3,5 Order number: 18 40 37 9

**PPP-Server with modem:**

Use a standard computer/ modem cable to connect the FP Web-Server to a modem:

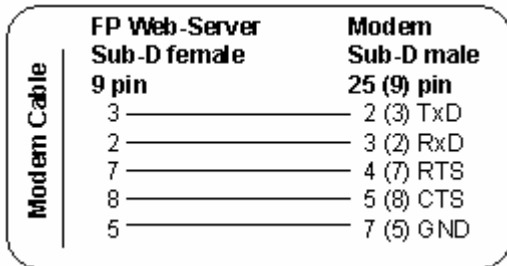

For the FP ISDN 64k or FP Modem 14.4 (both available from PEW Germany) use the following cable:

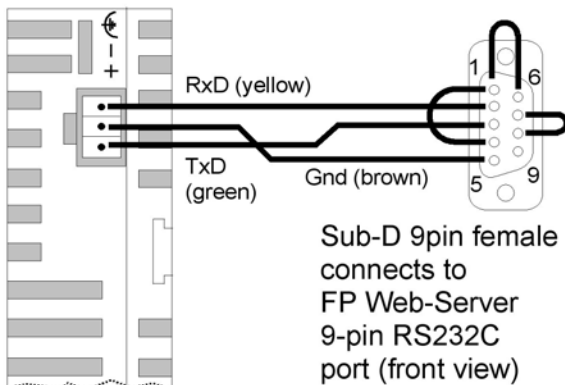

**PPP-Server without modem:**

Use a null modem cable to connect the FP Web-Server directly to a computer:

- A minimum, self-made adapter can be built by using two female connectors and 9-pin SUB-D connectors. The wiring should be as follows: 2-3; 3-2; 5-5. (This is the minimum number of wires required.)
- Or use a standard null modem adapter with full 25-pin, female RS232C connectors on both sides to create a connection between the FP Web-Server (with 25/9 adapter) and the computer's COM port.
- The full wiring of a standard 25-pin null modem adapter should be as follows: 1-1; 2-3; 3-2; 4+5-8; 6-20; 7-7; 8-4+5; 20-6.

### 15.3.3 Clearing Passwords

---

To reset the unit i.e. clear the password and the configuration of a FP Web-Server, carry out the following steps:



#### ◆ PROCEDURE

---

- 1. Press [FIND] and select the appropriate FP Web-Server by double-clicking**  
To select another unit, refer to the online help under Select from List of Units Found.
- 2. Press [INITIALIZE] to send the firmware and base configuration to the unit**
- 3. Press [SEND] (and optionally activate the "Web files" check box) to transfer the new configuration to the unit**
- 4. If requested, enter user name and password**

If you have forgotten the password, clear the password with DIP switch 4. For further questions, please contact your local Panasonic provider (see page 178).



## 15.4 IP and TCP/ IP

Every Ethernet participant must have an individual IP address. This address may not be used a second time in the same network. The IP address consists of 4 numbers (any 0 to 255). The first numbers define the network address, the other numbers define the participant's address.

### The Internet Address:

To be independent from the medium as well as the platform, one should not adjust the addressing of a single bus system when specifying the communication system. The concept of the Internet is based on one's own address, i.e. the Internet address. The Internet address is comprised of 32-bits and is divided into a network part and a participant's part. While the Ethernet address is displayed hexadecimally, for the most part, the decimal notation is normally used for the Internet address. Every byte is represented by its decimal value. Valid address specifications are numbers between 0 and 255.

<b>Example:</b>	0011 1001 /	0011 1101 /	111 0010 /	0001 1001
would be displayed as:	57.	61.	242.	25

Therefore, special address conventions have been agreed upon:

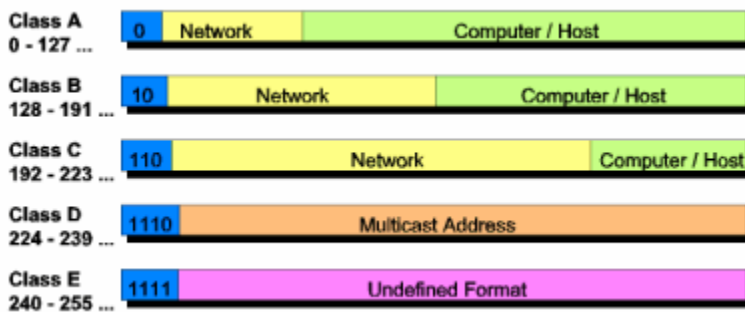

The following recipient's addresses are fixed:

- 255.255.255.255. broadcast "to all"
- Network address = 0 "the own network"

### Computer:

For information of the TCP/ IP installation on a Windows computer refer to the online help under TCP/ IP Setup for Configurator/Browser Operations via LAN.

### FP Web-Server:

The IP address of the FP Web-Server can be fixed or it can be allocated dynamically by a DHCP-Server. For more information refer to the online help under DHCP or Fixed IP Address.

The following two decisions can be made to set up the IP configuration of the FP Web-Server:

#### A) In a "self set-up" network (see page 168) (e.g. with only one hub) the fixed IP addresses can be assigned by yourself.

In many cases a class C network is used. The network is identified by 3 numbers.

The participants (Computers, Units, FP Web-Server...) are distinguished by the last number (1 to 254), e.g. 192.168.206.1 to 192.168.206.254.

In case this network is connected to a second network via a gateway (e.g. the computer for configuration might be in this network), the gateway address also needs to be specified, e.g.:

Computer in x.y.206.z Network with Netmask 255.255.255.0, using the x.y.206.1 Gateway.

FP Web-Server in x.y.60.z

The network should have the following settings:

- IP Add=x.y.60.31
- Netmask=255.255.255.0
- Gateway=x.y.60.1

**B) In case the FP Web-Server should be connected to an existing network, the following data must be asked from the network administrator:**

- Is there a DHCP-Server in the network? If NOT:
- IP address: Which fixed IP address can be assigned to the FP Web-Server?
- Netmask: How is the network address set up (length of the network address and/or the participant's address)?
- Gateway: What is the gateway's IP address? (0.0.0.0 if there is no gateway to be used).



---

◆ **REFERENCE**

For more detailed information refer to the online help under the keyword "TCP/ IP Setup for Configurator/Browser Operations via LAN".

## 15.5 Setup of an Individual Ethernet LAN

If no connection to an existing Ethernet network is used, you will find a couple of helpful remarks in the following paragraph.

### Private email server:

For using the email functions in such a "mini-network", an Email-Server has to be installed on the (or on one of the) computer. For example, on the Panasonic Ethernet exhibition board the Email-Server "1<sup>st</sup> Class Mail Server 2.0" by "1cis.com" was used successfully. For further information, refer to Details on the Email-Server (see page 64).

### Following two different Ethernet cables are used:

1. Direct 1:1 connection:

In the following example, only one computer should be used for carrying out the configuration of one or several FP Web-Servers:

If only one computer (with Ethernet card) should be connected with one FP Web-Server pier-to-pier, a crossover-cable can be used between the computer and the FP Web-Server. Please use the following pin allocation for setting up a cable for connecting two Ethernet network interfaces (hubs, cascading, FP Web-Server to computer, etc.):

- Ethernet (10-Base-T / 100-Base-Tx) use Standard Ethernet CAT.5 Crossover Cable:

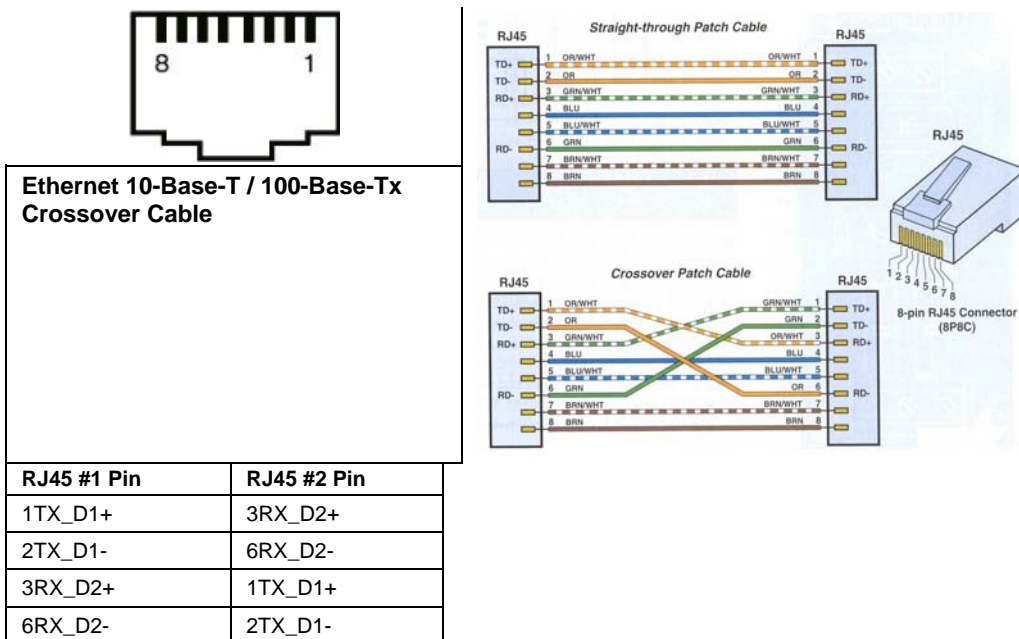

2. Standard network connection:

If more than one FP Web-Server should be connected with one (or several) computer, a hub or switch has to be used as a star coupler. A standard Ethernet 10BaseT hub can be used as a star coupler. When using a hub, you can use standard Ethernet twisted pair cables along with it.

### Hub or switch?:

If the IP address (and/or the data rate 10/ 100 MBPS) are not modified very often, a switch might increase the performance of the network in comparison to a hub:

A switch is an intelligent unit with which you can subdivide the Ethernet in sub-segments that are widely independent from each other. You can imagine it as a kind of switch matrix. If a piece of information should be transferred to another segment, the switch automatically establishes the respective connection. The other segments are not concerned by this data transfer and can be run in parallel operation mode. With the help of switches you can cut the likelihood of collisions drastically or even eliminate them totally (e.g. in the extreme case of a "totally switched" network).

Unfortunately, the case that several stations want to send a message to the same recipient cannot be defused by a switch. It has to be mentioned though that this special case cannot be controlled with the conventional, deterministic bus system either.

A switch receives a data package on one side. Based on the destination address, the unit decides via which output bus the message should be forwarded. You have to differentiate between switches that receive whole messages at once, analyze them and forward them afterwards ("Store and forward"), and other switches that are toggle controlled by the hardware as soon as the recipient's address is defined ("Cut through"). Of course, the latter ones are somewhat faster.

The price for this ideal way to avoid collisions has two aspects to consider:

First, switches are not cheap. There is a lot of processing effort behind them. Second, the effective wiring of the bus system is abandoned again and one returns to the traditional pier-to-pier connection. Consequently, the wiring effort is increased significantly.

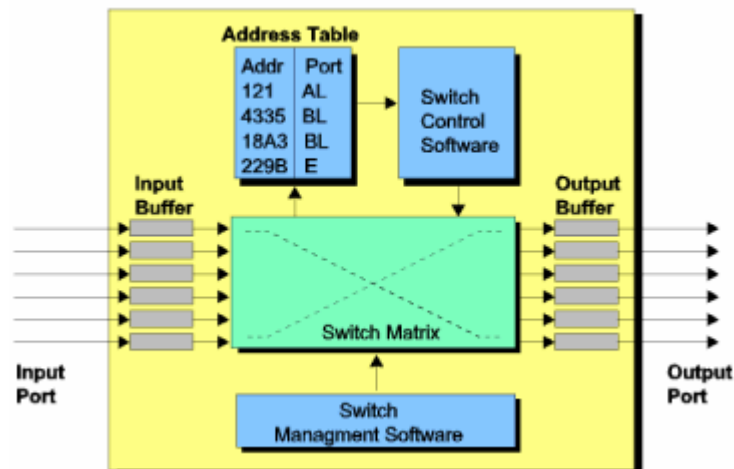

For generalities on TCP/ IP also refer to IP and TCP/ IP (see page 166).

## 15.6 Preinstalled Passwords and Safety Instructions

User name and password can be preset in the Configurator project.

Overview of the preset passwords:

Service	User Name:		Password:	
	Factory	Default	Factory	Default
Telnet	tel	user	tel	user
FTP	ftp	user	ftp	user
PPP	ppps	user	ppps	user
HTML Pages and PLC Data	web	user	web	user

The use of capital letter or small letters in the user name and passwords are not analyzed, i.e. the user name and password check are not case sensitive. User name and password should have 1 to 9 characters. Only ASCII characters are allowed. Do not use umlauts or Japanese characters.

### Exception:

For a remote dial-up connection (PPP connection) only lower case letters are to be entered for the password on the client's side. For further information also see Control Buttons/ User Name and Password.

To clear all passwords (and the complete configuration) see Clearing Passwords (see page 165).



### NOTES

1. **Always change the password. Leaving the default password can cause security problems. For the definition of the user name and the password see also Password Protection in the online help under the keyword "User Name and Password".**

Password Protection

user	User name
xxxxxxxx	Password

**2. The password of the PLC can be adjusted with the help of FPWIN Pro via Online → Security Settings**

The screenshot shows a web browser window titled "Security Settings". The interface is divided into three main sections:

- Status Information:** A box containing the text "Password protection: No password set or user logged in Hexadecimal (4 digits)".
- Password Function:** A section for changing the password. It includes the instruction "Please enter 4 hexadecimal digits" and three input fields: "Enter old password", "Enter new password", and "Repeat new password". To the right of these fields are two buttons: "Change" and "Clear".
- PLC Access:** A section for logging in. It includes the instruction "Please enter 4 hexadecimal digits" and one input field: "Enter password". To the right of this field are two buttons: "Login" and "Logout".

At the bottom of the window, there are two additional buttons: "Help" and "Close".

## 15.7 Troubleshooting

---



### ◆ NOTE

---

Some functions of the unit can be disabled with the function upload configuration with security options. This can cause some error messages if you try to change the configuration afterwards. Please check the security options (or reset (see page 165) the unit) if you discover problems in following situations:

- Unit is not listed with [Find] function
- Unit cannot be selected for configuration
- Unit does not accept new IP via UDP configuration
- No files can be transferred to the unit
- Unit cannot be restarted

### 15.7.1 Network Communication Problems

---

If you discover problems with the FP Web-Tool in finding (Button [Find]) and selecting (double-click) an FP Web-Server unit, please check the network settings.

#### **If an automatically generated IP address setting is to be used**

Make sure that the computer and the FP Web-Server's configuration is set up to use a DHCP server.



### ◆ PROCEDURE

---

1. Under "Settings / Network Connections", open the properties dialog of the computer's Ethernet/LAN card
2. Open the "Internet Protocol (TCP/IP)" properties dialog
3. Verify that the check box "Obtain IP address automatically" is set

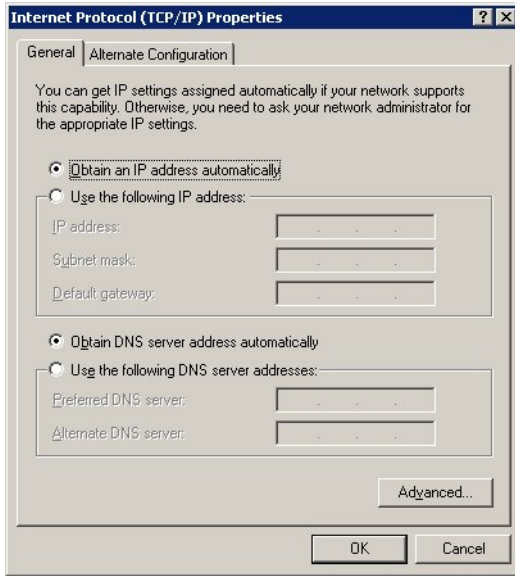

**4. Verify the FP Web-Server configuration in the FP Web-Configurator Tool under “Config”**

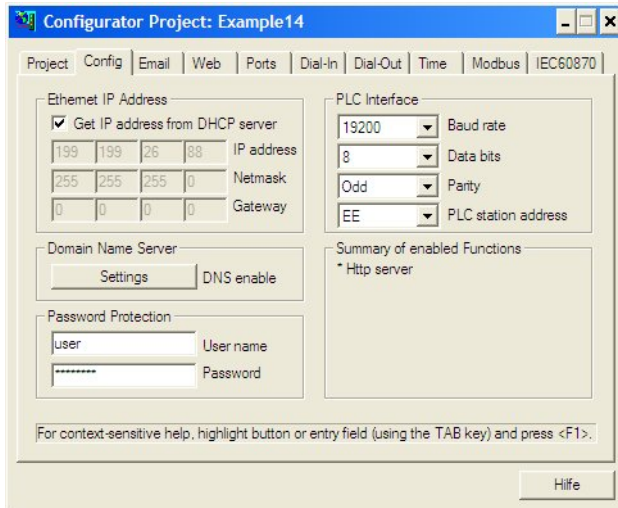

**If a static IP address setup should be used (private network or cross-over cable)**

Check the IP address settings of your computer and the FP Web-Server configuration.



**PROCEDURE**

- 1. Under "Settings / Network Connections", open the properties dialog of the computer's Ethernet/LAN card**
- 2. Open the “Internet Protocol (TCP/IP)” properties dialog**

The “Subnet mask” setting should be the same as with your FP Web-Server configuration. Also the left part of the “IP address” (identified by the 255 value in the



subnet mask) should be identical to the FP Web-Server configuration. However the right part of the computer's and FP Web-Server's "IP address" should be different.

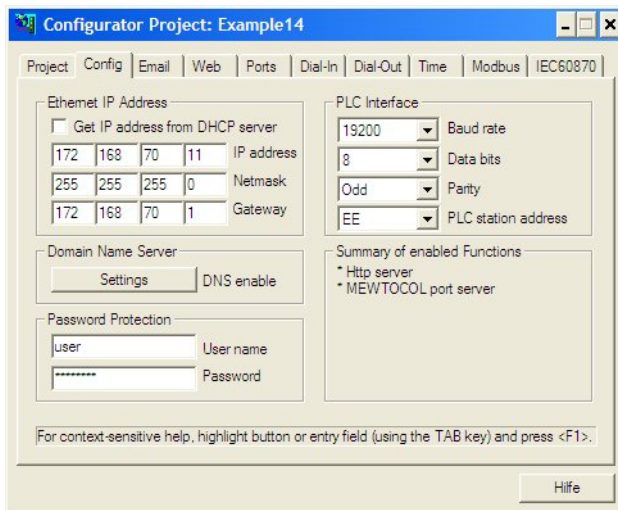
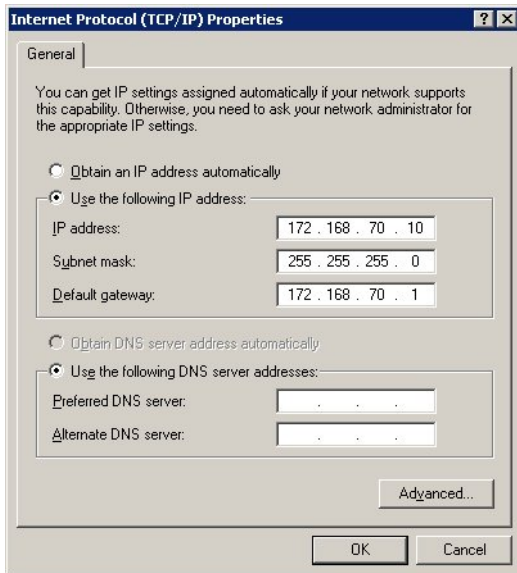

## 15.7.2 Problems Finding an FP Web-Server Unit or Unable to Send Configuration

If with FP Web-Tool, you cannot:

- find ([Find]) or select (double-click) an FP Web-Server unit
- send the configuration ([Send])
- send an HTML file ([Send File])

try the following:

- a) Disable the WindowsXP firewall on your LAN connection

For this go to "Settings / Network connections" and open the properties of the Ethernet/LAN card. Under "Advanced" disable the firewall function.

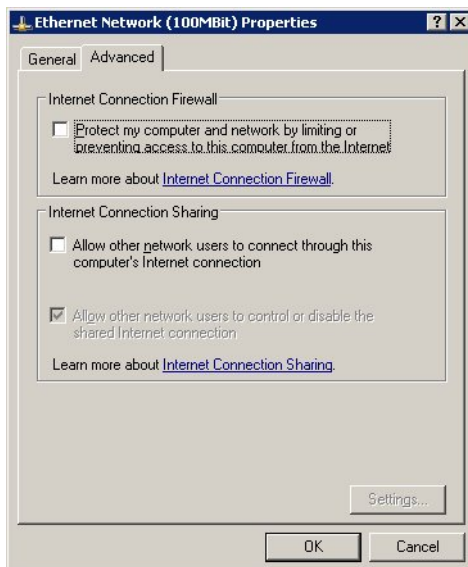

- b) If [Send] or [Send File] does not work

You receive an error message: "The computer is disconnected from the network". Start the Internet-Explorer, open "File" menu and remove the checkmark at "Work Offline".

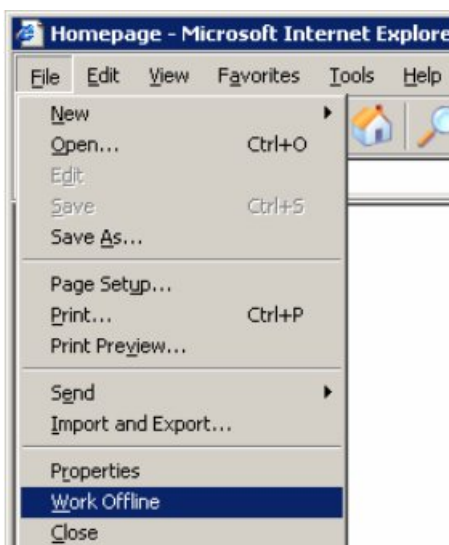

- c) Start the Internet-Explorer, open menu "Tools / Internet Options / Connections" and select "never dial a connection". Verify that there are valid settings in the sub-dialog "LAN Settings".

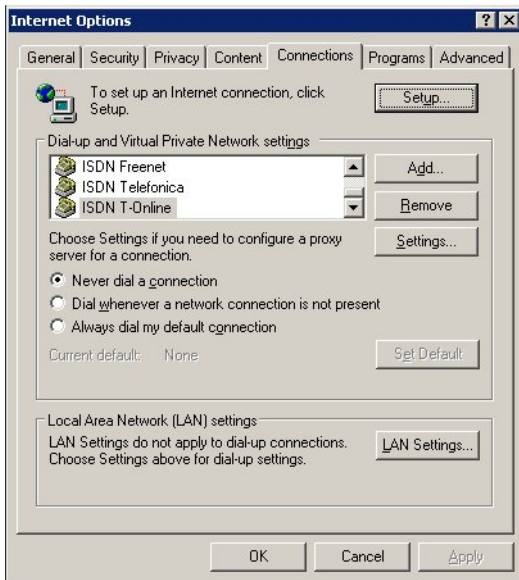

- d) Reset all Windows and Internet-Explorer security settings for a test.

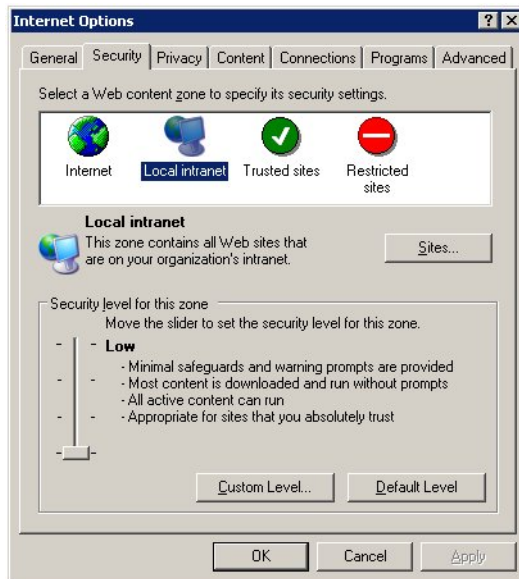

- e) Disable all additional firewall and security software packages. Especially disable virus scanner and spy software blocker for a test.

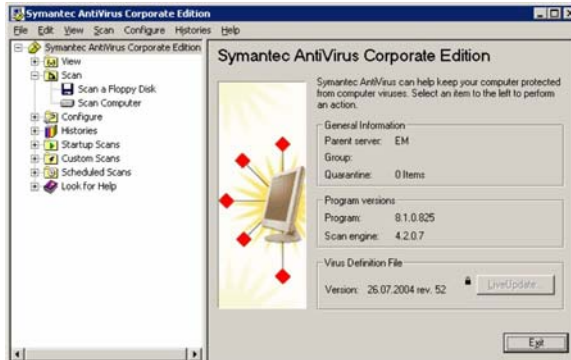

- f) Use the latest FP Web-Configurator Tool version.
- g) Edit the file "tool.ini" at "C:\Program Files\ Panasonic MEW Control\Configurator\ FP-WEB2" with Notepad. Change [FTP] PASSIV=1 from 0 to 1. And then test function again.
- h) Un-install all recently installed Windows security updates and patches for a test.

### 15.7.3 Panasonic Hotline

---

Should you have any problems, we would like to assist you as fast and effectively as possible.

If you have questions on the FP Web-Server that cannot be clarified with the documentation accompanying the product, please call your distributor:

#### Europe

Austria:	02236 / 2 68 46
Benelux:	0499 / 37 27 27
France:	01 / 60 13 57 57
Germany:	08024 / 648-748
Ireland:	01 / 4 60 09 69
Italy:	045 / 67 52 711
Scandinavia:	46 / 8 59 47 66 80
Spain:	91 / 3 29 38 75
Switzerland:	041 / 799 70 50
United Kingdom:	01908 / 23 15 55

#### North & South America

USA:	1 908 / 464 3550
------	------------------

#### Asia

China:	86 10 / 65 90 8646
Hong Kong:	852 / 2956 3118
Japan:	06 / 69 08 1050
Singapore:	65 / 255 5473

In case you find any errors in this documentation or cannot find important information, please do not hesitate to contact our department of technical documentation at [tech-doc@eu.pewg.panasonic.com](mailto:tech-doc@eu.pewg.panasonic.com)

Please also see the Configurator setup CD (start the setup) for further information on addresses of Panasonic distributors or visit Panasonic's website.

You can help us by having the following data at hand:

- Your product's **serial number** and **version number**. Both numbers are printed on the original disks. The version number is also indicated in the **System Menu => About Configurator** menu item.
- The **version numbers of MS-Windows and MS-DOS** which are installed on your computer.
- The type of **hardware** you are using.
- The exact **wording of any message that appears on your screen**.
- **What happened** and **what did you do** when the problem occurred?
- How did you attempt to solve the problem?

# Index

## (

(S)NTP Servers ..... 140

## A

Access Protection for Individual HTML Pages ..... 86  
Additional Information ..... 159  
Advantages and Functions of the FP Web-Server ..... 7  
Appendix ..... 159  
Appendix for Modbus Functions ..... 150  
ASCII Character Codes for Strings ..... 99  
Attachment to an email ..... 59  
Automatic Page Reload upon Submitting PLC Data ..... 94

## B

Base Configuration ..... 51  
BEFORE BEGINNING ..... i  
BEFORE YOU START ..... 2

## C

Cable Drawings ..... 162  
Cable Drawings and Modem ..... 163  
CD content ..... 160  
Clearing Passwords ..... 165  
Client's Side ..... 105  
Comments ..... 81  
Comments on Defining Input Fields for PLC Data on HTML ..... 91  
Compiling and Transferring HTML Pages ..... 76  
Configurator Http Administration and Functions ..... 100  
Configurator Settings Concerning the Http Server ..... 74  
Configurator Software ..... 45  
Connecting the Power Supply ..... 29  
Connection of the FP Web-Server ..... 34  
Contact Matsushita ..... 178  
Contents of the CD and Auxiliary Programs ..... 160  
Control Buttons for FP Web-Server Control ..... 49  
Control Buttons for the Administration of

the ..... 48

## D

Data Fields for Displaying PLC Data on HTML Pages ..... 77  
Defining Input Fields for PLC Data on HTML Pages ..... 87  
Description of the HTML Examples ..... 161  
Details of the IEC 60870 Configuration Modem and Multipoint Settings ..... 153  
Details on the FP Web-Server's Web Page Functions ..... 70  
Determination of the IP Configuration ... 36  
Dial-In Inputs and Parameters for PPP-Server ..... 127  
Dial-In Setup for PPP-Server ..... 109  
Dial-Out Setup for PPP-Client ..... 129  
Dial-up Networking Setup for Computer/ FP Web-Server ..... 110

## E

Editing HTML Pages ..... 75  
Email Configurator Input Fields ..... 68  
Email Function Used for Communication Tests ..... 60  
Email Functions of the FP Web-Server . 56  
Email Parameters in Configurator Projects ..... 56  
Email Server, how to find out its address 66  
Email Setup ..... 55  
Ethernet IP Configuration ..... 53  
Ethernet/ RS232C Ports ..... 103  
Example on Formatting Display and Input Fields ..... 92  
Example on Java Script Automations ... 95  
Examples on PLC Data Entries via HTML Page ..... 89  
Examples to Display PLC Data in an HTML Page ..... 79

## F

First Steps ..... 31  
FP Web-Server Block Diagram ..... 10  
FP Web-Server PPP Gateway Functions ..... 119  
FP Web-Server Unit Package ..... 16  
FPWIN Pro Setup to Use the Remote Dialup Network ..... 122  
Further Information ..... 43

**G**

General Information on the FP Web-Server Configurator.....	46
Generalities on How to Get Started .....	32
Generalities on PLC Data Fields in HTML Pages .....	72
Generalities on the Email-Server.....	64
Generalities on the Ethernet/ RS232C Ports .....	104
Generate a New Configurator Project....	37
Getting Started.....	1
GPRS Internet Connections .....	136

**H**

Hardware Description .....	13
Hardware Version .....	15
Hotline .....	178
How to Find out the Address of the Email Server.....	66
HTML examples, description of .....	161
Http Address, CGI Function PLC and Calling Parameter .....	73
Http Server Functions/ Web Pages .....	69

**I**

IEC 60870 Functions of the FP Web-Server .....	151
IEC 60870 General Functions .....	152
IEC 60870 Library for Control FPWIN Pro .....	156
IEC 60870 Parameters .....	155
Important Notes .....	21
Important Symbols .....	iii
Inputs for Controlling PLC internal relays on HTML Pages .....	87
Installation.....	20
Installation of the Configurator Program	35
Internet Browser Settings .....	72
Internet Browser to Test the FP Web-Server .....	41
Internet Dial-Out Settings .....	138
Internet Email Settings.....	130
Introduction .....	14
Introduction to FP Web-Server and the Java Applet.....	158
IP and TCP/ IP .....	166
ISDN Adapter.....	136

**J**

Java Applet Library .....	157
---------------------------	-----

**M**

Main Configuration.....	52
Mechanical Installation .....	24
Modbus Functions .....	143
Modbus-TCP Client of the FP Web-Servers in General.....	148
Modbus-TCP Server of the FP Web-Server in General.....	146
Modem and Dial-up Networking Installation of a Windows Client .....	111
Modem and Multipoint Settings .....	153

**N**

Network Communication Problems .....	172
New in This Version.....	4
Notes for Advanced Users.....	132
Notes on HTML Frames .....	97
Notes on Strings .....	90
Notes on XML Files with PLC Data .....	97
NTP Server for PLC Clock Synchronization .....	139

**O**

Overview on Modbus-TCP Functions of the FP Web-Server.....	144
--	-----

**P**

Panasonic Hotline .....	178
Parameters for IEC 60870 .....	155
Parts and Functions.....	17
PLC Connection.....	162
PLC Connection, Cable Drawings, Modem .....	162
PLC Data Attached to an Email.....	59
PLC Program with Function Block from the Library M_CE_LIB .....	61
PPP Communication via Null Modem Cable .....	123
PPP-Client Dial-Out Setup.....	138
PPP-Server Setup .....	127
Predefined Email Texts in the FP Web-Server .....	59
Preinstalled Passwords and Safety Instructions .....	170
Problems Finding an FP Web-Server Unit	

or Unable to Send Configuration..... 174  
Product Numbers and Versions..... 3

---

**R**

---

Record of Changes..... 182

---

**S**

---

Server's Side..... 104  
Setup of an Individual Ethernet LAN ... 168  
Setup of the Modem Connected to the FP  
Web-Server for PPP-Communication118  
System Requirements ..... 6  
System Sample Network ..... 11

---

**T**

---

TCP/ IP Network Installation of a Windows  
Client ..... 110  
Technical Data..... 19  
Testing the FP Web-Server Functions .. 70  
The Ethernet Network..... 33  
The Internet Dial-Out Function ..... 130  
Transfer a Configurator Project to the FP  
Web-Server ..... 39  
Troubleshooting..... 172

---

**U**

---

Using Variable Names Instead of Absolute  
PLC Addresses ..... 82

---

**W**

---

When Using a Cellular Phone (GSM)  
Modem ..... 135  
When Using ISDN Adapters ..... 136

---

**X**

---

XML general information..... 97



# Record of Changes

---

<b>Manual No.</b>	<b>Date</b>	<b>Description of Changes</b>
ACGM0151END	August 2001 March 2002	First European Edition Update of First European Edition: Optimized Graphics Corrected Errors
ACGM0151V1.1END	Sept. 2002	Complete update in accordance with hardware version 1.2
ACGM0151V1.2END	Okt. 2002	Changed pictures of configuration examples on pages 9-14 to 9-16
ACGM0151V1.3EN	July 2003	Complete update in accordance with software version 1.3. For details on the new information, see the section new in this version.
ACGM0151V2.0END	Okt. 2004	Complete update in accordance with software version 2.0. For details on the new information, see the section new in this version 2.0 in the online help.
ACGM0151V2.1END	Aug. 2005	Complete update in accordance with software version 2.1. For details on the new information, see the section new in this version 2.1 in the online help.
ACGM0151V2.2END	Dez. 2006	Complete update in accordance with software version 2.11. For details on the new information, see the section new in this version (see page 4).

# GLOBAL NETWORK



## North America

## Europe

## Asia Pacific

## China

## Japan

### Europe

- **Headquarters** **Panasonic Electric Works Europe AG**  
Rudolf-Diesel-Ring 2, 83607 Holzkirchen, Germany, Tel. (08024) 648-0, Fax (08024) 648-111, [www.panasonic-electric-works.com](http://www.panasonic-electric-works.com)
- **Austria** **Panasonic Electric Works Austria GmbH**  
Josef Madersperger Straße 2, A-2362 Biedermannsdorf, Austria, Tel. (02236) 26846, Fax (02236) 46133, [www.panasonic-electric-works.at](http://www.panasonic-electric-works.at)
- **Benelux** **Panasonic Electric Works Sales Western Europe B. V.**  
De Rijn 4, (Postbus 211), 5684 PJ Best, (5680 AE Best), Netherlands, Tel. (0499) 37 27 27, Fax (0499) 37 21 85, [www.panasonic-electric-works.nl](http://www.panasonic-electric-works.nl)
- **Czech Republic** **Panasonic Electric Works Czech s.r.o.**  
Prumyslová 1, 34815 Planá, Tel. (0374) 79 99 90, Fax (0374) 79 99 99, [www.panasonic-electric-works.cz](http://www.panasonic-electric-works.cz)
- **France** **Panasonic Electric Works Sales Western Europe B. V. French Branch Office**  
B.P. 44, F-91371 Verrières le Buisson CEDEX, France, Tél. 01 60 13 57 57, Fax 01 60 13 57 58, [www.panasonic-electric-works.fr](http://www.panasonic-electric-works.fr)
- **Germany** **Panasonic Electric Works Deutschland GmbH**  
Rudolf-Diesel-Ring 2, 83607 Holzkirchen, Germany, Tel. (08024) 648-0, Fax (08024) 648-555, [www.panasonic-electric-works.de](http://www.panasonic-electric-works.de)
- **Ireland** **Panasonic Electric Works UK Ltd. Irish Branch Office**  
Dublin, Republic of Ireland, Tel. (01) 4600969, Fax (01) 4601131, [www.panasonic-electric-works.ie](http://www.panasonic-electric-works.ie)
- **Italy** **Panasonic Electric Works Italia s.r.l.**  
Via del Commercio 3-5 (Z.I. Ferlina), I-37012 Bussolengo (VR), Italy, Tel. (045) 675 27 11, Fax (045) 6 70 04 44, [www.panasonic-electric-works.it](http://www.panasonic-electric-works.it)
- **Nordic Countries** **Panasonic Electric Works Nordic AB**  
Sjöängsvägen 10, 19272 Sollentuna, Sweden, Tel. (+46) 8 59 47 66 80, Fax (+46) 8 59 47 66 90, [www.panasonic-electric-works.se](http://www.panasonic-electric-works.se)
- **Portugal** **Panasonic Electric Works Portugal España S.A. Portuguese Branch Office**  
Avda Adelino Amaro da Costa 728 R/C J, 2750-277 Cascais, Portugal, Tel. (351) 21 481 25 20, Fax (351) 21 481 25 29, [www.panasonic-electric-works.es](http://www.panasonic-electric-works.es)
- **Spain** **Panasonic Electric Works España S.A.**  
Parque Empresarial Barajas, San Severo, 20, 28042 Madrid, Spain, Tel. (91) 329 38 75, Fax (91) 329 29 76, [www.panasonic-electric-works.es](http://www.panasonic-electric-works.es)
- **Switzerland** **Panasonic Electric Works Schweiz AG**  
Grundstrasse 8, CH-6343 Rotkreuz, Switzerland, Tel. (041) 799 70 50, Fax (041) 799 70 55, [www.panasonic-electric-works.ch](http://www.panasonic-electric-works.ch)
- **UK** **Panasonic Electric Works UK Ltd.**  
Sunrise Parkway, Linford Wood East, Milton Keynes, MK14 6LF, England, Tel. (01908) 231 555, Fax (01908) 231 599, [www.panasonic-electric-works.co.uk](http://www.panasonic-electric-works.co.uk)

### North & South America

- **USA** **PEW Corporation of America Head Office USA**  
629 Central Avenue, New Providence, N.J. 07974, USA, Tel. 1-908-464-3550, Fax 1-908-464-8513

### Asia

- **China** **Panasonic Electric Works (China) Co., Ltd.**  
2013, Beijing Fortune, Building 5, Dong San Huan Bei Lu, Chaoyang District, Beijing, China, Tel. 86-10-6590-8646, Fax 86-10-6590-8647
- **Hong Kong** **Panasonic Electric Works (Hong Kong) Co., Ltd.**  
Rm1601, 16/F, Tower 2, The Gateway, 25 Canton Road, Tsimshatsui, Kowloon, Hong Kong, Tel. (852) 2956-3118, Fax (852) 2956-0398
- **Japan** **Matsushita Electric Works, Ltd.**  
1048 Kadoma, Kadoma-shi, Osaka 571-8686, Japan, Tel. 06-6908-1050, Fax 06-6908-5781, [www.mew.co.jp/e-acg/](http://www.mew.co.jp/e-acg/)
- **Singapore** **Panasonic Electric Works Asia Pacific Pte. Ltd.**  
101 Thomson Road, #25-03/05, United Square, Singapore 307591, Tel. (65) 6255-5473, Fax (65) 6253-5689